

Hydronit



**2011
AC & DC Hydraulic
Power Packs Compact**

POWER PACKS COMPACT series ordering code

MODEL CODE

Example:

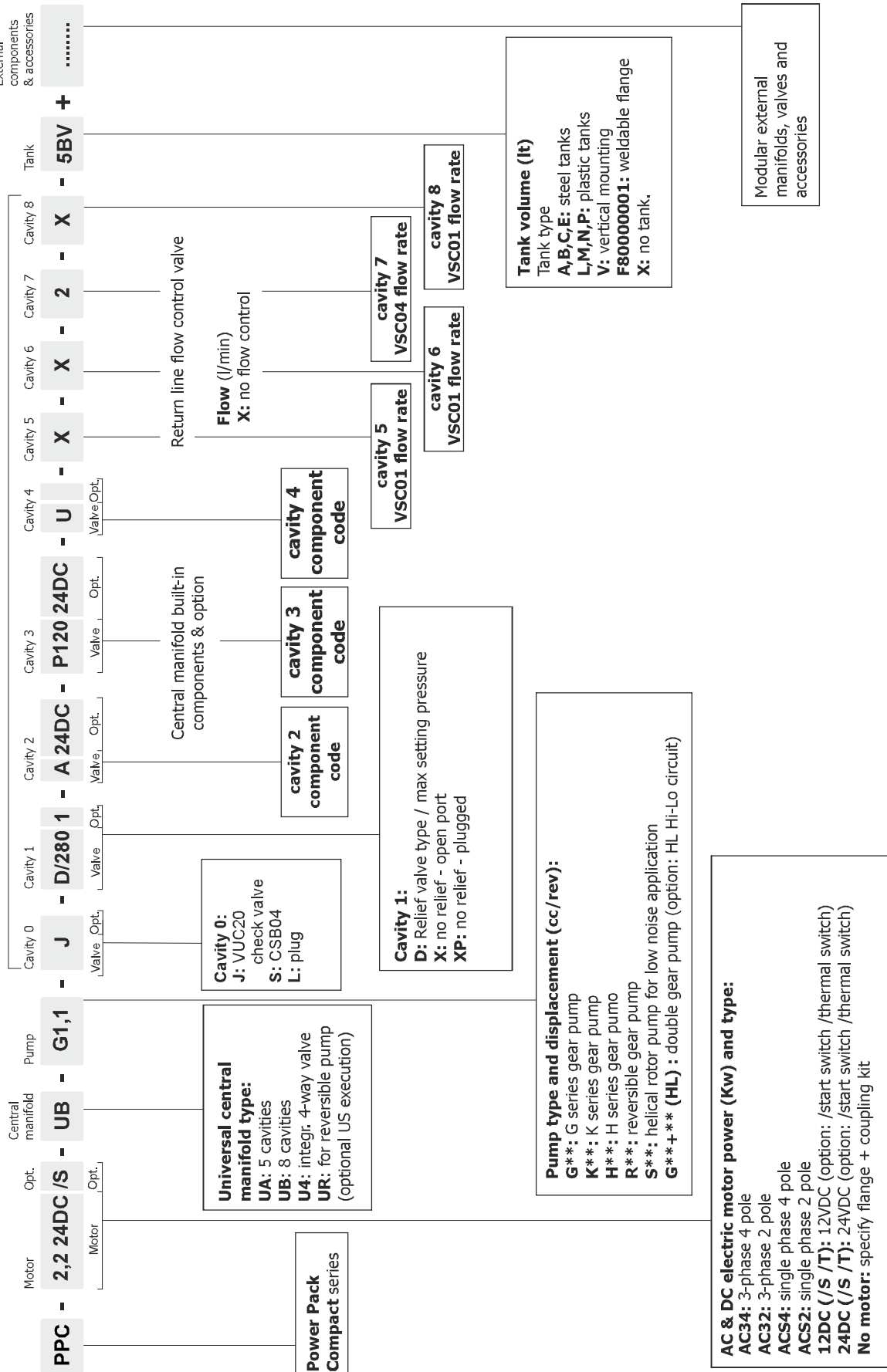

QUICK SELECTION GUIDE

AC & DC electric motors

Section A

DC motors

0,15 12DC_T	12VDC motor - 150W - Ø 80 + thermal switch
0,15 24DC_T	24VDC motor - 150W - Ø 80 + thermal switch
0,5 12DC	12VDC motor - 500W - Ø 80
0,5 24DC	24VDC motor - 500W - Ø 80
0,5 12DC_T	12VDC motor - 500W - Ø 80 + thermal switch
0,5 24DC_T	24VDC motor - 500W - Ø 80 + thermal switch
0,8 12DC	12VDC motor - 800W - Ø 80
0,8 24DC	24VDC motor - 800W - Ø 80
0,8 12DC_T	12VDC motor - 800W - Ø 80 + thermal switch
0,8 24DC_T	24VDC motor - 800W - Ø 80 + thermal switch
1,6 12DC_T	12VDC motor - 1600W - Ø 114 + thermal switch
2,1 12DC_T	12VDC motor - 2100W - Ø 114 + thermal switch
2,2 24DC_T	24VDC motor - 2200W - Ø 114 + thermal switch
2,4 12DC_T	12VDC motor - 2400W - Ø 125 fan cooled + thermal switch
3 24DC_T	24VDC motor - 3000W - Ø 125 fan cooled + thermal switch
2,5HD 12DC_T	12VDC motor - 2500W - Ø 151 fan cooled B14-90 frame + thermal switch
3HD 24DC_T	24VDC motor - 3000W - Ø 151 fan cooled B14-90 frame + thermal switch
4HD 24DC_T	24VDC motor - 4000W - Ø 151 fan cooled B14-90 frame + thermal switch



AC motors: three-phase 4 poles (~1450 rpm @ 50Hz / ~1750 rpm @ 60Hz)

E037AC341S3	integral motor 0,37kW S3 3-ph 4-pole 220/380V 50/60Hz frame 71
E055AC341S3	integral motor 0,55kW S3 3-ph 4-pole 220/380V 50/60Hz frame 71
E075AC341S3	integral motor 0,75kW S3 3-ph 4-pole 220/380V 50/60Hz frame 71
E075AC342S3	integral motor 0,75kW S3 3-ph 4-pole 220/380V 50/60Hz frame 80
E110AC342S3	integral motor 1,1kW S3 3-ph 4-pole 220/380V 50/60Hz frame 80
E150AC343S3	integral motor 1,5kW S3 3-ph 4-pole 220/380V 50/60Hz frame 90
E220AC343S3	integral motor 2,2kW S3 3-ph 4-pole 220/380V 50/60Hz frame 90
E300AC343S3	integral motor 3kW S3 3-ph 4-pole 220/380V 50/60Hz frame 90



AC motors: single-phase 4 poles (~1450 rpm at 50Hz)

E037ACS41S3	integral motor 0,37kW S3 1-ph 4-pole 220V 50Hz frame 71
E055ACS41S3	integral motor 0,55kW S3 1-ph 4-pole 220V 50Hz frame 71
E055ACS42S3	integral motor 0,55kW S3 1-ph 4-pole 220V 50Hz frame 80
E075ACS42S3	integral motor 0,75kW S3 1-ph 4-pole 220V 50Hz frame 80
E110ACS43S3	integral motor 1,1kW S3 1-ph 4-pole 220V 50Hz frame 90
E150ACS43S3	integral motor 1,5kW S3 1-ph 4-pole 220V 50Hz frame 90
E220ACS43S3	integral motor 2,2kW S3 1-ph 4-pole 220V 50Hz frame 90



2 pole and special execution motors (High starting torque, high IP, with thermal protector,... available on request)

AC & DC electric motors

B14 AC motors

B14550AC324S3	B14 motor 5,5kW S3 3-ph 2-pole 220/380V 50/60Hz frame 100
B14750AC325S3	B14 motor 7,5kW S3 3-ph 2-pole 220/380V 50/60Hz frame 112
B14400AC344S3	B14 motor 4kW S3 3-ph 4-pole 220/380V 50/60Hz frame 100
B14550AC344S3	B14 motor 5,5kW S3 3-ph 4-pole 220/380V 50/60Hz frame 100
B14750AC345S3	B14 motor 5,5kW S3 3-ph 4-pole 220/380V 50/60Hz frame 112
B14300ACS44S3	B14 motor 3kW S3 1-ph 4-pole 220V 50Hz frame 100
B14400ACS24S3	B14 motor 4kW S3 1-ph 2-pole 220V 50Hz frame 100



No motor: B14 Flange + coupling kit

XB14 71-0	mounting kit PPC for B14 motors frame 71 with pump group 0
XB14 80-0	mounting kit PPC for B14 motors frame 80 with pump group 0
XB14 71-1	mounting kit PPC for B14 motors frame 71 with pump group 1
XB14 80-1	mounting kit PPC for B14 motors frame 80 with pump group 1
XB14 90-1	mounting kit PPC for B14 motors frame 90 with pump group 1
XB14 100-1	mounting kit PPC for B14 motors frame 100/112 with pump group 1
X56C-0	mounting kit PPC for Nema 56C-face motors with pump group 0
X56C-1	mounting kit PPC for Nema 56C-face motors with pump group 1



Electric motors options

DC motor options

S150 12DC 80	starting relay 12VDC 150A with mounting kit for Ø 80 motors
S150 24DC 80	starting relay 24VDC 150A with mounting kit for Ø 80 motors
S150 12DC 112	starting relay 12VDC 150A with mounting kit for Ø 112-114 motors
S150 24DC 112	starting relay 24VDC 150A with mounting kit for Ø 112-114 motors
S200 12DC	starting relay 12VDC 200A for Ø 125 and Ø 151 motors
S200 24DC	starting relay 24VDC 200A for Ø 125 and Ø 151 motors



Universal central manifold

Section B

International execution (1/4" BSP exit ports)

UA	Universal A type PPC body with 3 lateral cavities
UB	Universal B type PPC body with 5 lateral cavities
U4	Universal 4 type PPC body for 4 way cartridge valves
UR	Universal R type PPC body for reversible pump

USA execution (SAE 06 exit ports)

UAUS	Universal A type PPC body with 3 lateral cavities US execution
UBUS	Universal B type PPC body with 5 lateral cavities US execution
U4US	Universal 4 type PPC body for 4 way cartridge valves US execution
URUS	Universal R type PPC body for reversible pump US execution



QUICK SELECTION GUIDE

Section C

Gear Pumps

G type gear pumps

G0,8	gear pump group 1 – 0,85 cc/rev G series
G1,1	gear pump group 1 – 1,15 cc/rev G series
G1,3	gear pump group 1 – 1,3 cc/rev G series
G1,6	gear pump group 1 – 1,6 cc/rev G series
G2,1	gear pump group 1 – 2,1 cc/rev G series
G2,6	gear pump group 1 – 2,6 cc/rev G series
G3,2	gear pump group 1 – 3,2 cc/rev G series
G3,7	gear pump group 1 – 3,7 cc/rev G series
G4,2	gear pump group 1 – 4,2 cc/rev G series
G4,9	gear pump group 1 – 4,9 cc/rev G series
G6,0	gear pump group 1 – 6,0 cc/rev G series
G7,9	gear pump group 1 – 7,9 cc/rev G series
G9,8	gear pump group 1 – 9,8 cc/rev G series



K type gear pumps

K0,2	gear pump group 0 – 0,26 cc/rev K series + adaptor flange for group 0 pump
K0,4	gear pump group 0 – 0,38 cc/rev K series + adaptor flange for group 0 pump
K0,6	gear pump group 0 – 0,64 cc/rev K series + adaptor flange for group 0 pump
K0,9	gear pump group 1 – 0,89 cc/rev K series
K1,2	gear pump group 1 – 1,27 cc/rev K series
K1,6	gear pump group 1 – 1,66 cc/rev K series
K2,1	gear pump group 1 – 2,17 cc/rev K series
K2,7	gear pump group 1 – 2,8 cc/rev K series
K3,2	gear pump group 1 – 3,3 cc/rev K series
K3,7	gear pump group 1 – 3,8 cc/rev K series
K4,2	gear pump group 1 – 4,3 cc/rev K series
K5,0	gear pump group 1 – 5,1 cc/rev K series
K6,0	gear pump group 1 – 6,0 cc/rev K series
K7,9	gear pump group 1 – 7,9 cc/rev K series



H type high pressure gear pumps

H1,2	gear pump group 1 high pressure – 1,2 cc/rev H series
H1,7	gear pump group 1 high pressure – 1,7 cc/rev H series
H2,2	gear pump group 1 high pressure – 2,2 cc/rev H series
H2,6	gear pump group 1 high pressure – 2,6 cc/rev H series
H3,2	gear pump group 1 high pressure – 3,2 cc/rev H series
H3,8	gear pump group 1 high pressure – 3,8 cc/rev H series
H4,2	gear pump group 1 high pressure – 4,3 cc/rev H series
H4,7	gear pump group 1 high pressure – 4,7 cc/rev H series



QUICK SELECTION GUIDE

Gear Pumps

Double gear pumps with Hi-Lo system

K0,9+3,2HL	HI-LO double pump - 0,9 + 3,3cc/rev K series
K1,2+5HL	HI-LO double pump - 1,2 + 5cc/rev K series

Bidirectional gear pumps

R0,2	Reversible gear pump group 0-0,26 cc/rev + adaptor flange for group 0 pump
R0,4	reversible gear pump - 0,38cc/rev + adaptor flange for group 0 pump
R0,6	reversible gear pump - 0,63cc/rev + adaptor flange for group 0 pump
R0,9	reversible gear pump - 0,88cc/rev + adaptor flange for group 0 pump
R1,3	reversible gear pump - 1,25cc/rev + adaptor flange for group 0 pump
R1,5	reversible gear pump - 1,5cc/rev + adaptor flange for group 0 pump
R2,1	Reversible gear pump group 1 - 2,1 cc/rev
R2,6	Reversible gear pump group 1 - 2,6 cc/rev

Helical rotor pumps for high pressure and low noise and low pulsation applications

S4,2	low noise helical rotor pump group 1 - 4,2cc/rev
S6,4	low noise helical rotor pump group 1 - 6,4cc/rev
S8,3	low noise helical rotor pump group 1 - 8,3cc/rev
S10	low noise helical rotor pump group 1 - 10,2cc/rev
S13	low noise helical rotor pump group 1 - 12,9cc/rev



Integral components: Cavity 0

Components in central manifold cavity 0

J	check valve ball type 3/4-16UNF
S	flow control valve 3/4-16UNF with screw
L	plug 3/4-16UNF basic
N	plug 3/4-16UNF open passage with 1/4" BSPP exit port

Cavity 0 option

EP01	exit port ¼ BSPP
EM9001C	pressure gauge shut-off valve 90° F-F + nipples M 1/4" BSPP – M 1/4" BSPP
EMIL01C	pressure gauge shut-off valve F-F + nipples M 1/4" BSPP – M 1/4" BSPP
F401**J	pressure switch 1/4" BSPP where ** = max setting pressure (050-100-200-400 bar)
MIR63**EM	pressure gauge Ø63 where ** = max press. (60-160-250-315 bar) + shut-off valve 90°

Section D



Integral components: Cavity 1

Components in central manifold cavity 1

D_60	guided needle relief valve M20x1,5 - 10÷60 bar - socket screw adj.
D_180	guided needle relief valve M20x1,5 - 20÷180 bar - socket screw adj.
D_280	guided needle relief valve M20x1,5 - 35÷280 bar - socket screw adj.
D_350	Guided needle relief valve M20x1,5 - 50÷350 bar - socket screw adj.
XP	closed plug for relief valve M20x1,5 cavity



QUICK SELECTION GUIDE

Cavity 1 option

2	handwheel M8 for VMDC35/VMDC20/VCF6 valves
3	steel cap for VMDC35 relief valve
4	plastic seal for VMDC35 relief valve

Integral components: Cavity 2

Components in central manifold cavity 2

X	open cavity – no valve
A	NC solenoid 2/2 way 3/4-16UNF poppet valve
B	NC solenoid 2/2 way 3/4-16UNF poppet valve with emergency
C	NO solenoid 2/2 way 3/4-16UNF poppet valve with emergency
D	NC solenoid 2/2 way 3/4-16UNF double poppet valve with emergency
E	lever operated 2/2 way valve without micro-switch
EM	lever operated 2/2 way valve with micro-switch
Z	2 way emergency button valve
S	flow control valve 3/4-16UNF with screw
T12DC	proportional flow control valve poppet type 15l/min 315 bar + coil 12VDC ED100%
T24DC	proportional flow control valve poppet type 15l/min 315 bar + coil 24VDC ED100%
U	hand pump 3/4-16UNF 2 cc/stroke + suction/return line pipe 1/4" BSP 370mm
G	closed plug 3/4-16UNF
H	plug 3/4-16UNF with 1/4" BSPP exit port
N	plug 3/4-16UNF open passage with 1/4" BSPP exit port
P	plug 3/4-16UNF passing through 1/4" BSPP
L	plug 3/4-16UNF basic
J	check valve ball type 3/4-16UNF
4VA11C	4/2 way solenoid directional valve, closed center transient (only for U4 manifolds)
4VA2	4/3 way solenoid directional valve, center P to T (only for U4 manifolds)
4VB2	4/3 way solenoid directional valve, closed center (only for U4 manifolds)
4VC2	4/3 way solenoid directional valve, H center (only for U4 manifolds)
4VE2	4/3 way solenoid directional valve, center A-B to T (only for U4 manifolds)



Cavity 2 option

V-CSB	handwheel for CSB/CSU
EM9001C	pressure gauge shut-off valve 90° F-F + nipples M 1/4" BSPP – M 1/4" BSPP
EMIL01C	pressure gauge shut-off valve F-F + nipples M 1/4" BSPP – M 1/4" BSPP
F401**	pressure switch 1/4" BSPP where ** = max setting pressure (050-100-200-400 bar)
MIR63**EM	pressure gauge Ø63 where ** = max press. (60-160-250-315 bar) + shut-off valve 90°



Cavity 2 valve coil

12DC_M130	Coil 12V DC 18W ED75% for MSV30-31 + Electric connector DIN 43650-A
24DC_M130	Coil 24V DC 18W ED75% for MSV30-31 + Electric connector DIN 43650-A
24RAC_M130	Coil 24V DC 18W ED75% for MSV30-31 + El. connector with rectifier 12-24V
115_50AC_M130	Coil 115V/50Hz AC 28VA ED75% only for MSV30 + El. connector DIN 43650-A
230_50AC_M130	Coil 230V/50Hz AC 28VA ED75% only for MSV30 + El. connector DIN 43650-A
110RAC_M130	Coil 110V RAC 18W ED75% for MSV30-31 + El. connector with rectifier 115 V
220RAC_M130	Coil 220V RAC 18W ED75% for MSV30-31 + El. connector with rectifier 230 V



QUICK SELECTION GUIDE

Cavity 2 valve coil

12DC_M140	Coil 12V DC 22W ED100% for MSV-MDV + Electric connector DIN 43650-A
24DC_M140	Coil 24V DC 22W ED100% for MSV-MDV + Electric connector DIN 43650-A
24RAC_M140	Coil 24V DC 22W ED100% for MSV-MDV + El. connector with rectifier 12-24 V
110RAC_M140	Coil 110V RAC 22W ED100% for MSV-MDV + El. connector with rectifier 115 V
220RAC_M140	Coil 220V RAC 22W ED100% for MSV-MDV + El. connector with rectifier 230 V
12DC_M630	coil 12V DC ED100% + Electric connector DIN 43650-A
24DC_M630	coil 24V DC ED100% + Electric connector DIN 43650-A
24AC_M631	coil 24V AC ED100% with integrated rectifier + Electric connector DIN 43650-A
115AC_M631	coil 115V AC ED100% with integrated rectifier + Electric connector DIN 43650-A
230AC_M631	coil 230V AC ED100% with integrated rectifier + Electric connector DIN 43650-A



Integral components: Cavity 3

Components in central manifold cavity 3

F02	fixed pressure compensated flow control valve 3/4-16UNF hole 0,8mm
F03	fixed pressure compensated flow control valve 3/4-16UNF hole 1mm
F04	fixed pressure compensated flow control valve 3/4-16UNF hole 1,25mm
F05	fixed pressure compensated flow control valve 3/4-16UNF hole 1,5mm
F06	fixed pressure compensated flow control valve 3/4-16UNF hole 1,75mm
F07	fixed pressure compensated flow control valve 3/4-16UNF hole 2mm
F09	fixed pressure compensated flow control valve 3/4-16UNF hole 2,5mm
F11	fixed pressure compensated flow control valve 3/4-16UNF hole 3mm
F13	fixed pressure compensated flow control valve 3/4-16UNF hole 3,5mm
F15	fixed pressure compensated flow control valve 3/4-16UNF hole 4mm
R2	compensated flow control valve 3/4-16UNF with screw 1 ÷ 2,2 l/min
R3	compensated flow control valve 3/4-16UNF with screw 1,6 ÷ 4 l/min
R4	compensated flow control valve 3/4-16UNF with screw 2,5 ÷ 5 l/min
R5	compensated flow control valve 3/4-16UNF with screw 3 ÷ 7 l/min
R6	compensated flow control valve 3/4-16UNF with screw 4,9 ÷ 10,8 l/min
R7	compensated flow control valve 3/4-16UNF with screw 8 ÷ 18,5 l/min
S	flow control valve 3/4-16UNF with screw
Z	2 way emergency button valve
AR	NC solenoid 2/2 way 3/4-16UNF poppet valve with reversible flow
BR	NC solenoid 2/2 way 3/4-16UNF poppet valve +emergency with reversible flow
CR	NO solenoid 2/2 way 3/4-16UNF poppet valve + emergency with reversible flow
D	NC solenoid 2/2 way 3/4-16UNF double poppet valve with emergency
J	check valve ball type 3/4-16UNF
G	closed plug 3/4-16UNF
H	plug 3/4-16UNF with 1/4"BSPP exit port
N	plug 3/4-16UNF open passage with 1/4"BSPP exit port
P	plug 3/4-16UNF passing through 1/4"BSPP
L	plug 3/4-16UNF basic
P**12DC	proportional relief valve 3/4-16UNF 12VDC where ** = max pressure (60-210 bar)
P**24DC	proportional relief valve 3/4-16UNF 24VDC where ** = max pressure (60-210 bar)
V**	relief valve 3/4-16UNF where ** = max pressure (40-110-250-350 bar) - socket screw



QUICK SELECTION GUIDE

Cavity 3 option

V-CSB	handwheel for CSB/CSU
2	handwheel M8 for VMDC35/VMDC20/VCF6 valves
EM9001C	pressure gauge shut-off valve 90° F-F + nipples M 1/4" BSPP – M 1/4" BSPP
EMIL01C	pressure gauge shut-off valve F-F + nipples M 1/4" BSPP – M 1/4" BSPP
F401**	pressure switch 1/4" BSPP where ** = max setting pressure (050-100-200-400 bar)
MIR63**EM	pressure gauge Ø63 where ** = max press. (60-160-250-315 bar) + shut-off valve 90°



Cavity 3 valve coil voltage

12DC_M130	Coil 12V DC 18W ED75% for MSV30-31 + Electric connector DIN 43650-A
24DC_M130	Coil 24V DC 18W ED75% for MSV30-31 + Electric connector DIN 43650-A
24RAC_M130	Coil 24V DC 18W ED75% for MSV30-31 + El. connector with rectifier 12-24 V
115_50AC_M130	Coil 115V/50Hz AC 28VA ED75% only for MSV30 + Electric connector DIN 43650-A
230_50AC_M130	Coil 230V/50Hz AC 28VA ED75% only for MSV30 + Electric connector DIN 43650-A
110RAC_M130	Coil 110V RAC 18W ED75% for MSV30-31 + El. connector with rectifier 115 V
220RAC_M130	Coil 220V RAC 18W ED75% for MSV30-31 + El. connector with rectifier 230 V
12DC_M140	Coil 12V DC 22W ED100% for MSV-MDV + Electric connector DIN 43650-A
24DC_M140	Coil 24V DC 22W ED100% for MSV-MDV + Electric connector DIN 43650-A
24RAC_M140	Coil 24V DC 22W ED100% for MSV-MDV + El. connector with rectifier 12-24 V
110RAC_M140	Coil 110V RAC 22W ED100% for MSV-MDV + El. connector with rectifier 115 V
220RAC_M140	Coil 220V RAC 22W ED100% for MSV-MDV + El. connector with rectifier 230 V



Integral components: Cavity 4

Component in central manifold cavity 4

A	NC solenoid 2/2 way 3/4-16UNF poppet valve
B	NC solenoid 2/2 way 3/4-16UNF poppet valve with emergency
C	NO solenoid 2/2 way 3/4-16UNF poppet valve with emergency
D	NC solenoid 2/2 way 3/4-16UNF double poppet valve with emergency
E	lever operated 2/2 way valve without micro-switch
EM	lever operated 2/2 way valve with micro-switch
Z	2 way emergency button valve
S	flow control valve 3/4-16UNF with screw
T12DC	proportional flow control valve poppet type 15l/min 315 bar + coil 12VDC ED100%
T24DC	proportional flow control valve poppet type 15l/min 315 bar + coil 24VDC ED100%
U	hand pump 3/4-16UNF 2 cc/stroke + suction/return line pipe 1/4"BSP 370mm
G	closed plug 3/4-16UNF
H	plug 3/4-16UNF with 1/4"BSPP exit port
N	plug 3/4-16UNF open passage with 1/4"BSPP exit port
P	plug 3/4-16UNF passing through 1/4"BSPP
L	plug 3/4-16UNF basic
J	check valve ball type 3/4-16UNF



QUICK SELECTION GUIDE

Cavity 4 option

V-CSB	handwheel for CSB/CSU
EM9001C	pressure gauge shut-off valve 90° F-F + nipples M 1/4" BSPP – M 1/4" BSPP
EMIL01C	pressure gauge shut-off valve F-F + nipples M 1/4" BSPP – M 1/4" BSPP
F401**	pressure switch 1/4" BSPP where ** = max setting pressure (050-100-200-400 bar)
MIR63**EM	pressure gauge Ø63 where ** = max press. (60-160-250-315 bar) + shut-off valve 90°



Cavity 4 valve coil voltage

12DC_M130	Coil 12V DC 18W ED75% for MSV30-31 + Electric connector DIN 43650-A
24DC_M130	Coil 24V DC 18W ED75% for MSV30-31 + Electric connector DIN 43650-A
24RAC_M130	Coil 24V DC 18W ED75% for MSV30-31 + El. connector with rectifier 12-24 V
115_50AC_M130	Coil 115V/50Hz AC 28VA ED75% only for MSV30 + Electric connector DIN 43650-A
230_50AC_M130	Coil 230V/50Hz AC 28VA ED75% only for MSV30 + Electric connector DIN 43650-A
110RAC_M130	Coil 110V RAC 18W ED75% for MSV30-31 + El. connector with rectifier 115 V
220RAC_M130	Coil 220V RAC 18W ED75% for MSV30-31 + El. connector with rectifier 230 V
12DC_M140	Coil 12V DC 22W ED100% for MSV-MDV + Electric connector DIN 43650-A
24DC_M140	Coil 24V DC 22W ED100% for MSV-MDV + Electric connector DIN 43650-A
24RAC_M140	Coil 24V DC 22W ED100% for MSV-MDV + El. connector with rectifier 12-24 V
110RAC_M140	Coil 110V RAC 22W ED100% for MSV-MDV + El. connector with rectifier 115 V
220RAC_M140	Coil 220V RAC 22W ED100% for MSV-MDV + El. connector with rectifier 230 V



Flow restrictor in central manifold cavity 5

Flow restrictor in central manifold cavity 5

PLUGTCE01	1/4" BSPP plug with copper washer
PP01370	suction/return line pipe 1/4"BSP 370mm
RETURN-KIT	1/4" BSP holder for SF12 + flexible plastic pipe 12 mm for return line / price per meter
C34200001	return line tank immersed filter
1(01)	fixed pressure compensated flow control valve 1/4"BSP 1l/min
2(01)	fixed pressure compensated flow control valve 1/4"BSP 2l/min
3(01)	fixed pressure compensated flow control valve 1/4"BSP 3l/min
4(01)	fixed pressure compensated flow control valve 1/4"BSP 4l/min
5(01)	fixed pressure compensated flow control valve 1/4"BSP 5l/min
6(01)	fixed pressure compensated flow control valve 1/4"BSP 6l/min
8(01)	fixed pressure compensated flow control valve 1/4"BSP 8l/min
10(01)	fixed pressure compensated flow control valve 1/4"BSP 10l/min
12(01)	fixed pressure compensated flow control valve 1/4"BSP 12l/min
15(01)	fixed pressure compensated flow control valve 1/4"BSP 15l/min



Flow restrictor in central manifold cavity 6

Flow restrictor in central manifold cavity 6

PLUGTCE01	1/4" BSPP plug with copper washer
PP01370	suction/return line pipe 1/4"BSP 370mm
RETURN-KIT	1/4" BSP holder for SF12 + flexible plastic pipe 12 mm for return line / price per meter
C34200001	return line tank immersed filter
1(01)	fixed pressure compensated flow control valve 1/4"BSP 1l/min
2(01)	fixed pressure compensated flow control valve 1/4"BSP 2l/min
3(01)	fixed pressure compensated flow control valve 1/4"BSP 3l/min
4(01)	fixed pressure compensated flow control valve 1/4"BSP 4l/min
5(01)	fixed pressure compensated flow control valve 1/4"BSP 5l/min
6(01)	fixed pressure compensated flow control valve 1/4"BSP 6l/min
8(01)	fixed pressure compensated flow control valve 1/4"BSP 8l/min
10(01)	fixed pressure compensated flow control valve 1/4"BSP 10l/min
12(01)	fixed pressure compensated flow control valve 1/4"BSP 12l/min
15(01)	fixed pressure compensated flow control valve 1/4"BSP 15l/min



Flow restrictor in central manifold cavity 7

Flow restrictor in central manifold cavity 7

0(04)	closed plug for cavity 7
1(04)	fixed pressure compensated flow control valve 1/4"BSP 1l/min
2(04)	fixed pressure compensated flow control valve 1/4"BSP 2l/min
3(04)	fixed pressure compensated flow control valve 1/4"BSP 3l/min
4(04)	fixed pressure compensated flow control valve 1/4"BSP 4l/min
5(04)	fixed pressure compensated flow control valve 1/4"BSP 5l/min
6(04)	fixed pressure compensated flow control valve 1/4"BSP 6l/min
8(04)	fixed pressure compensated flow control valve 1/4"BSP 8l/min
10(04)	fixed pressure compensated flow control valve 1/4"BSP 10l/min
12(04)	fixed pressure compensated flow control valve 1/4"BSP 12l/min
15(04)	fixed pressure compensated flow control valve 1/4"BSP 15l/min



Flow restrictor in central manifold cavity 8

Flow restrictor in central manifold cavity 8

PLUGTCE01	1/4" BSPP plug with copper washer
PP01370	suction/return line pipe 1/4"BSP 370mm
RETURN-KIT	1/4" BSP holder for SF12 + flexible plastic pipe 12 mm for return line / price per meter
C34200001	return line tank immersed filter
1(01)	fixed pressure compensated flow control valve 1/4"BSP 1l/min
2(01)	fixed pressure compensated flow control valve 1/4"BSP 2l/min
3(01)	fixed pressure compensated flow control valve 1/4"BSP 3l/min
4(01)	fixed pressure compensated flow control valve 1/4"BSP 4l/min
5(01)	fixed pressure compensated flow control valve 1/4"BSP 5l/min
6(01)	fixed pressure compensated flow control valve 1/4"BSP 6l/min
8(01)	fixed pressure compensated flow control valve 1/4"BSP 8l/min
10(01)	fixed pressure compensated flow control valve 1/4"BSP 10l/min
12(01)	fixed pressure compensated flow control valve 1/4"BSP 12l/min
15(01)	fixed pressure compensated flow control valve 1/4"BSP 15l/min



QUICK SELECTION GUIDE

Tanks

Section E

Steel tanks

1,5A	1,5l cylindrical steel tank horizontal mounting + 1/2"BSPP std filler & breather plug
1,5AV	1,5l cylindrical steel tank vertical mounting + 1/2"BSPP std filler & breather plug
2,5A	2,5l cylindrical steel tank horizontal mounting + 1/2"BSPP std filler & breather plug
2,5AV	2,5l cylindrical steel tank vertical mounting + 1/2"BSPP std filler & breather plug
5B	5l cylindrical steel tank horizontal mounting + 1/2"BSPP std filler & breather plug
5BV	5l cylindrical steel tank vertical mounting + 1/2"BSPP std filler & breather plug
10B	10l cylindrical steel tank horizontal mounting + 1/2"BSPP std filler & breather plug
10BV	10l cylindrical steel tank vertical mounting + 1/2"BSPP std filler & breather plug
12B	12l cylindrical steel tank horizontal mounting + 1/2"BSPP std filler & breather plug
12BV	12l cylindrical steel tank vertical mounting + 1/2"BSPP std filler & breather plug
10C	10l square steel tank horizontal mounting + 1/2"BSPP std filler & breather plug
10CV	10l square steel tank vertical mounting + 1/2"BSPP std filler & breather plug
22C	22l square steel tank horizontal mounting + 3/4"BSPP male filler & breather plug
22CV	22l square steel tank vertical mounting + 3/4"BSPP male filler & breather plug
3EV	3l vertical square steel tank vertical mounting + 1/2"BSPP std filler & breather plug
7EV	7l vertical square steel tank vertical mounting + 1/2"BSPP std filler & breather plug
8EV	8l vertical square steel tank vertical mounting + 3/4"BSPP male filler & breather plug
15EV	15l vertical square steel tank vertical mounting + 3/4"BSPP male filler & breather plug
20EV	20l vertical square steel tank vertical mounting + 3/4"BSPP male filler & breather plug
30EV	30l vertical square steel tank vertical mounting + 3/4"BSPP male filler & breather plug
F80000001	steel tank adapter for PPC - to be welded on custom made tanks



Plastic tanks

1,5L	1,5l square plastic tank type L horizontal mounting + 3/4"BSPP F filler & breather plug
1,5LV	1,5l square plastic tank type L vertical mounting + 3/4"BSPP F filler & breather plug
3L	3l square plastic tank type L horizontal mounting + 3/4"BSPP F filler & breather plug
3LV	3l square plastic tank type L vertical mounting + 3/4"BSPP F filler & breather plug
6L	6l square plastic tank type L horizontal mounting + 3/4"BSPP F filler & breather plug
6LV	6l square plastic tank type L vertical mounting + 3/4"BSPP F filler & breather plug
5M	5l square plastic tank 170mm type M horizontal mounting + 3/4"BSPP F filler & breather
5MV	5l square plastic tank 170mm type M vertical mounting + 3/4"BSPP F filler & breather
8M	8l square plastic tank 170mm type M horizontal mounting + 3/4"BSPP F filler & breather
8MV	8l square plastic tank 170mm type M vertical mounting + 3/4"BSPP F filler & breather
5P	5l round plastic tank for PPC Ø195mm horizontal mounting + 1/2"BSPP filler & breather
5PV	5l round plastic tank for PPC Ø195mm vertical mounting + 1/2"BSPP filler & breather
9P	9l round plastic tank for PPC Ø195mm horizontal mounting + 1/2"BSPP filler & breather
9PV	9l round plastic tank for PPC Ø195mm vertical mounting + 1/2"BSPP filler & breather
12N	12l square plastic tank 180mm type N horizontal mounting + 1/2"BSPP filler & breather
12NV	12l square plastic tank 180mm type N vertical mounting + 1/2"BSPP filler & breather



QUICK SELECTION GUIDE

Accessories

Accessories

E60543006	foot mounting support 45mm
E60543007	foot mounting support tall type (67mm)
MIR63**	pressure gauge Ø63 where ** = max press. (60-160-250-315 bar)
EM9001C	pressure gauge shut-off valve 90° F-F + nipples M 1/4" BSPP – M 1/4" BSPP
EMIL01C	pressure gauge shut-off valve F-F + nipples M 1/4" BSPP – M 1/4" BSPP
F16000001	plastic Ø112-114 DC motor protection cover
F401**	pressure switch 1/4" BSPP where ** = max setting pressure (050-100-200-400 bar)
F4ROM3	pressure switch 1/8" BSPP 0,2-2,5bar for filter manifold E60403020
MIR4010	pressure gauge Ø40 10bar max for filter manifold E60403020
P0201	remote up/down control with 3m flying cable for single/double acting cylinder
P0202	remote 4 buttons control with 3m flying cable for 2 double acting cylinders
VPC00	electronic PWM driver for proportional valves 12/24VDC
BFCSAE0801	in-line manifolds for 3/4-16UNF valves 1/4" BSPP ports
BFCSAE0802	in-line manifolds for 3/4-16UNF valves 3/8" BSPP ports



External manifolds

External manifolds

E60403004	28mm spacer subplate
E60403005	90° rotation manifold
E60403001	NG6 (cetop 3) parallel block - 3/8" BSPP rear ports (9/16-18UNF for US)
E60403010	NG6 (cetop 3) parallel block - 3/8" BSPP lateral ports (9/16-18UNF for US)
E60403011	NG6 (cetop 3) series block - 3/8" BSPP lateral ports (9/16-18UNF for US)
E60413002	NG6 (cetop 3) manifold with piloted check valve on A
E60413001	NG6 (cetop 3) manifold with piloted check valve on A and B
E60413003	NG6 (cetop 3) manifold with piloted check valve on B
E60403027	modular manifold with piloted check valves on A and B
E60403028	modular manifold with check valve for differential area cylinder
E60403020	modular basic manifold for spin-on return filter on T line
PM09	hand pump 8,8 cc/stroke – cartridge only + base modular manifold
E60403006	PPC to SD01 converter (needed to mount SD01 stackable valves)
E60403008M	PPC to PPM base converter (needed to mount SD00 NG3 MICRO valves)
M60403010	PPM NG3 MICRO modular manifold with 1/4" BSPP lateral ports (9/16-18UNF for US)
M60403004	PPM spacer element
M60403005	PPM 90° rotation manifold
M60413002	PPM NG3 MICRO modular manifold with piloted check valves on A
M60413001	PPM NG3 MICRO modular manifold with piloted check valves on A and B
M60413003	PPM NG3 MICRO modular manifold with piloted check valves on B
E60403030	manifold for MSV or MDV 2/2 way cartridge valves
E60403031	manifold for MSV3V 3/2 way cartridge valve

Section F



QUICK SELECTION GUIDE

External valves

External valves

MSV3V4000000	3/2 way solenoid cartridge valve, A to T de-energized
MSV3000000	NC solenoid 2/2 way 3/4-16UNF poppet valve
MSV30E0000	NC solenoid 2/2 way 3/4-16UNF poppet valve with emergency
MSV31E0000	NO solenoid 2/2 way 3/4-16UNF poppet valve with emergency
MDV30E0000	NC solenoid 2/2 way 3/4-16UNF double poppet valve with emergency
SD00A11C	NG3 MICRO solenoid directional valve 4 way, 2 positions
SD00A2	NG3 MICRO solenoid directional valve 4 way, 3 pos. center P to T
SD00B2	NG3 MICRO solenoid directional valve 4 way, 3 pos. closed center
SD00C2	NG3 MICRO solenoid directional valve 4 way, 3 pos. H center
SD00E2	NG3 MICRO solenoid directional valve 4 way, 3 pos. center A-B to T
SD01A11C	Stackable solenoid directional valve 4 way, 2 positions
SD01A2	Stackable solenoid directional valve 4 way, 3 pos. center P to T
SD01B2	Stackable solenoid directional valve 4 way, 3 pos. closed center
SD01C2	Stackable solenoid directional valve 4 way, 3 pos. H center
SD01E2	Stackable solenoid directional valve 4 way, 3 pos. center A-B to T
SD01A11CC	Stackable solenoid directional valve 4 way, 2 positions, stack top closed
SD01A2C	Stackable solenoid directional valve 4 way, 3 pos. center P to T, stack top closed
SD01B2C	Stackable solenoid directional valve 4 way, 3 pos. closed center, stack top closed
SD01C2C	Stackable solenoid directional valve 4 way, 3 pos. H center, stack top closed
SD01E2C	Stackable solenoid directional valve 4 way, 3 pos. center A-B to T, stack top closed
SD03A11C	NG6 (cetop3) solenoid directional valve 4 way, 2 positions
SD03A2	NG6 (cetop3) solenoid directional valve 4 way, 3 pos. center P to T
SD03B2	NG6 (cetop3) solenoid directional valve 4 way, 3 pos. closed center
SD03C2	NG6 (cetop3) solenoid directional valve 4 way, 3 pos. H center
SD03E2	NG6 (cetop3) solenoid directional valve 4 way, 3 pos. center A-B to T
HD03A1	NG6 (cetop3) manual directional valve, spring centered P to T
HD03A2	NG6 (cetop3) manual directional valve, spring centered closed center
HD03A3	NG6 (cetop3) manual directional valve, spring centered H center
HD03A10	NG6 (cetop3) manual directional valve, spring centered A-B to T
HD03D1	NG6 (cetop3) manual directional valve, detent, center P to T
HD03D2	NG6 (cetop3) manual directional valve, detent, closed center
HD03D3	NG6 (cetop3) manual directional valve, detent, H center
HD03D10	NG6 (cetop3) manual directional valve, detent, center A-B to T
E60423001L	NG6 (cetop3) sandwich type modular valve with relief valve on A & B 60bar max
E60423001A	NG6 (cetop3) sandwich type modular valve with relief valve on A & B 180bar max
E60423001B	NG6 (cetop3) sandwich type modular valve with relief valve on A & B 280bar max
E60423002L	NG6 (cetop3) sandwich type modular valve with relief valve on A 60bar max
E60423002A	NG6 (cetop3) sandwich type modular valve with relief valve on A 180bar max
E60423002B	NG6 (cetop3) sandwich type modular valve with relief valve on A 280bar max
E60423003L	NG6 (cetop3) sandwich type modular valve with relief valve on B 60bar max
E60423003A	NG6 (cetop3) sandwich type modular valve with relief valve on B 180bar max
E60423003B	NG6 (cetop3) sandwich type modular valve with relief valve on B 280bar max
E60433001	NG6 (cetop3) sandwich type modular valve with unidirectional throttle valve on A & B
E60433002	NG6 (cetop3) sandwich type modular valve with unidirectional throttle valve on A
E60433003	NG6 (cetop3) sandwich type modular valve with unidirectional throttle valve on B

Section G



QUICK SELECTION GUIDE

External cartridge valves coils

12DC_M130	Coil 12V DC 18W ED75% for MSV30-31 + Electric connector DIN 43650-A
24DC_M130	Coil 24V DC 18W ED75% for MSV30-31 + Electric connector DIN 43650-A
24RAC_M130	Coil 24V DC 18W ED75% for MSV30-31 + El. connector with rectifier 12-24 V
115_50AC_M130	Coil 115V/50Hz AC 28VA ED75% only for MSV30 + Electric connector DIN 43650-A
230_50AC_M130	Coil 230V/50Hz AC 28VA ED75% only for MSV30 + Electric connector DIN 43650-A
110RAC_M130	Coil 110V RAC 18W ED75% for MSV30-31 + El. connector with rectifier 115 V
220RAC_M130	Coil 220V RAC 18W ED75% for MSV30-31 + El. connector with rectifier 230 V
12DC_M140	Coil 12V DC 22W ED100% for MSV-MDV + Electric connector DIN 43650-A
24DC_M140	Coil 24V DC 22W ED100% for MSV-MDV + Electric connector DIN 43650-A
24RAC_M140	Coil 24V DC 22W ED100% for MSV-MDV + El. connector with rectifier 12-24 V
110RAC_M140	Coil 110V RAC 22W ED100% for MSV-MDV + El. connector with rectifier 115 V
220RAC_M140	Coil 220V RAC 22W ED100% for MSV-MDV + El. connector with rectifier 230 V



External SD00 valves coils

12DC_M100	coil 12V DC 16W ED100% + Electric connector DIN 43650-A
24DC_M100	coil 24V DC 16W ED100% + Electric connector DIN 43650-A



External SD01 valves coils

12DC_M120	coil 12V DC 22W ED100% + Electric connector DIN 43650-A
24DC_M120	coil 24V DC 22W ED100% + Electric connector DIN 43650-A
24RAC_M120	coil 24V DC 22W ED100% + El. conn. with rectifier 12-24 V black pg11
220RAC_M120	coil 220V RAC 26W ED100% + El. conn. with rectifier 230 V black pg11



External SD03 valves coils

12DC_M160	coil 12V DC 26W ED100% + Electric connector DIN 43650-A
24DC_M160	coil 24V DC 26W ED100% + Electric connector DIN 43650-A
24RAC_M160	coil 24V DC 26W ED100% + El. conn. DIN 43650-A with rectifier 12-24 V black pg11
110RAC_M160	coil 110V RAC 26W ED100% + El. conn. DIN 43650-A with rectifier 115 V black pg11
220RAC_M160	coil 220V RAC 26W ED100% + El. conn. DIN 43650-A with rectifier 230 V black pg11

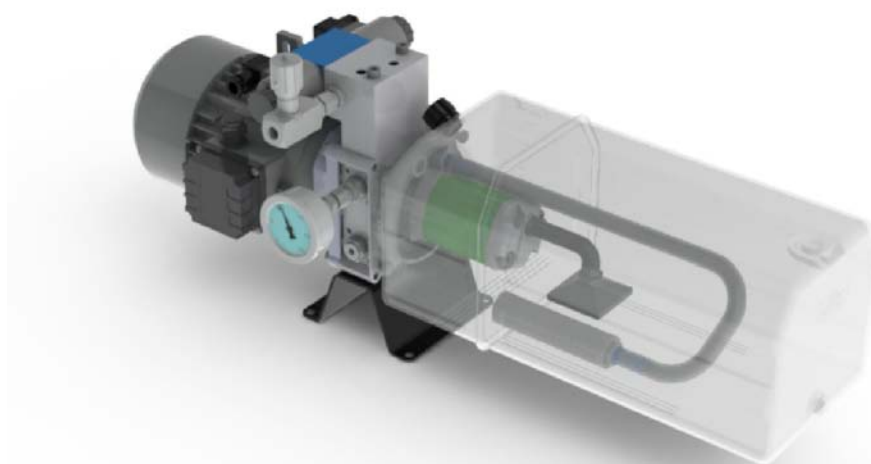

AC & DC ELECTRIC MOTORS

Integral AC motors: the engineered solution for compact and optimised power units from 0,25 to 4 kW, single or three phase, 4 or 2 poles. These AC motors are **directly flanged** on the central manifold for extra compactness. A **single tang drive coupling** can suit all frame sizes and powers.

We suggest to adopt these advanced motors because of their peculiar advantages over standard B14 AC motors and because they are designed specifically for our mini power packs, offering an **higher power density** and **high starting torque** (in HT models) than market standard motors. These motors are intended for intermittent duty (S3 40%), which is the case for most mini-power packs applications. They can be used in emergency situations continuously at a reduced rated power (30% less than S3 nominal power).

Single phase motors, due to their peculiar construction, should not run without load for long time to avoid overheating.



B14 IEC standard AC motors: the standard solution easily available on every market from 0,25 to 7,5 kW, single or three phase. These motors are normally procured by the customer itself. Hydronit provides adaptor flanges and double piece coupling for frame sizes: 71, 80, 90, 100 and 112.

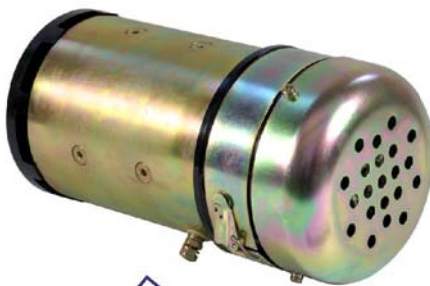

Frame 151 DC motors: real heavy duty bulk motors, with fan cooling, thermal protector and running time up to 16 min or over. Power from 2,5kW 12VDC up to 4kW 24VDC.



Frame 114 DC motors: the most popular choice. Power up to 2,1kW 12VDC and 2,2kW 24VDC. All motors have thermal protector switch as standard.

Are AC motors compliant with the European Union Minimum Energy Performance Standards?

Hydronit AC motors are manufactured in Italy with the best technologies nowadays available and are specifically designed for mini power packs duties, which are typically intermittent. Hydronit motors have an higher power density, lower weight, lower cost, comparing to standard IE2 motors on the market. Due to the specific field of applications, Hydronit motors are not included in the requirements of the above mentioned normative, since they are specially and solely manufactured for mini power packs intermittent duties. For continuous duty applications IE2 motors (IEC 60034-30) must be applied. Ask our sales office.

Are there special requirements to mount IEC B14 motors?

No special toolings are required. Please strictly follow motor side coupling mounting dimension tolerance as per the relevant drawings. Failing in doing so may cause malfunctioning of the power pack and even the break of the coupling and pump.

Can I start single phase AC motors under load?

Single phase motors have a reduced starting torque due to their intrinsic design. Normally this ranges around 30-40% of the nominal torque at full power output. When designing circuits where a single phase motor must start under load, a proper dimensioning must be done and test on field must be preliminary performed. High starting torque «HT» motors are available. Ask our technical office.

How do I dimension a DC motor?

These motors are normally for intermittent duty. It is important to know required flow in l/min, working pressure in bar and the duty charge. Then following A060 table instructions a proper motor/pump combination can be selected.

INTEGRAL DC MOTORS Ø 80

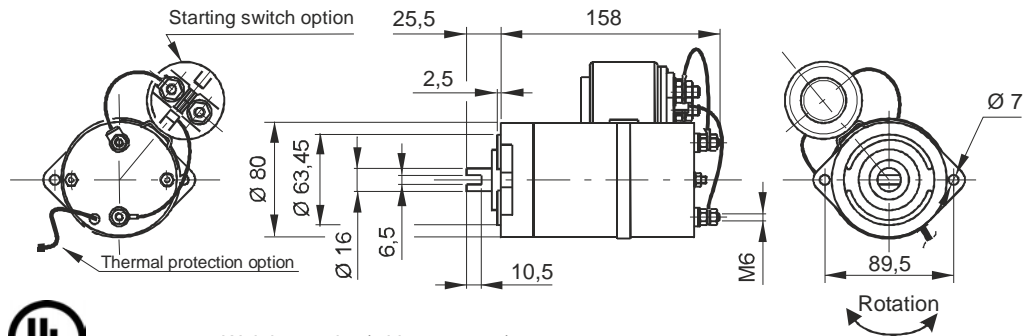

Permanent magnets
Protection degree: IP54
Insulation class: F



Weight: 2,6 kg (without starter)

Code

Description	PPC assembly code	Spare part code	Nominal duty cycle	Nominal speed	Nominal current
150W 12V DC + thermal protector	0,15 12DC/T	M46C1ST01	S2: 10 min S3: 15% ED	1400 rpm	30 A
150W 24V DC + thermal protector	0,15 24DC/T	M46C2ST01	S2: 10 min S3: 15% ED	1400 rpm	15 A
500W 12V DC motor	0,5 12DC	M46C1S005	S2: 6 min S3: 10% ED	2800 rpm	90 A
500W 24V DC motor	0,5 24DC	M46C2S005	S2: 6 min S3: 10% ED	2800 rpm	50 A
500W 12V DC + thermal protector	0,5 12DC/T	M46C1ST05	S2: 6 min S3: 10% ED	2800 rpm	90 A
500W 24V DC + thermal protector	0,5 24DC/T	M46C2ST05	S2: 6 min S3: 10% ED	2800 rpm	50 A
800W 12V DC motor	0,8 12DC	M46C1S008	S2: 3 min S3: 10% ED	4000 rpm	130 A
800W 24V DC motor	0,8 24DC	M46C2S008	S2: 4 min S3: 10% ED	4000 rpm	80 A
800W 12V DC + thermal protector	0,8 12DC/T	M46C1ST08	S2: 3 min S3: 10% ED	4000 rpm	130 A
800W 24V DC + thermal protector	0,8 24DC/T	M46C2ST08	S2: 4 min S3: 10% ED	4000 rpm	80 A

Options & couplings

Description	PPC assembly code	Spare part code
12V DC 150 Amp start switch + mounting kit	S150 12DC 80	M47SC0001 + M47SK0801
24V DC 150 Amp start switch + mounting kit	S150 24DC 80	M47SC0002 + M47SK0801
Remote wired control with 2 buttons and 3m cable	P0201 (single acting)	
Remote wired control with 4 buttons and 3m cable	P0202 (double acting)	
Coupling for Ø 80 DC motors and gr.1 pump	E36200002	
Coupling for Ø 80 DC motors and gr.0 pump	E36200006	

Notes: the starting switch mounting kit is provided when specifying the /S150 as motor option in PPC assembly code. When ordering spare starting switches, it must be ordered separately (code: M47SK0801).

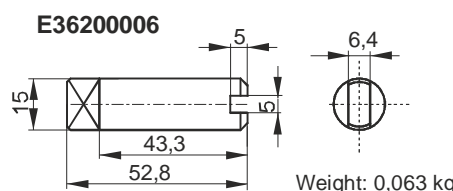
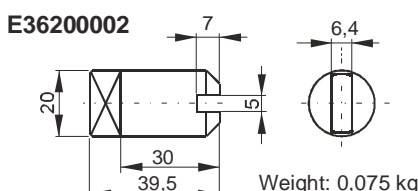

The coupling is already included when specifying the motor in PPC assembly code. It is to be indicated only when ordering PPC with no motor but with coupling.

INTEGRAL DC MOTORS Ø 114



Compound wound
 Protection degree: IP54
 Insulation class: F
 Weight: 7,05 kg (without starter)



Code

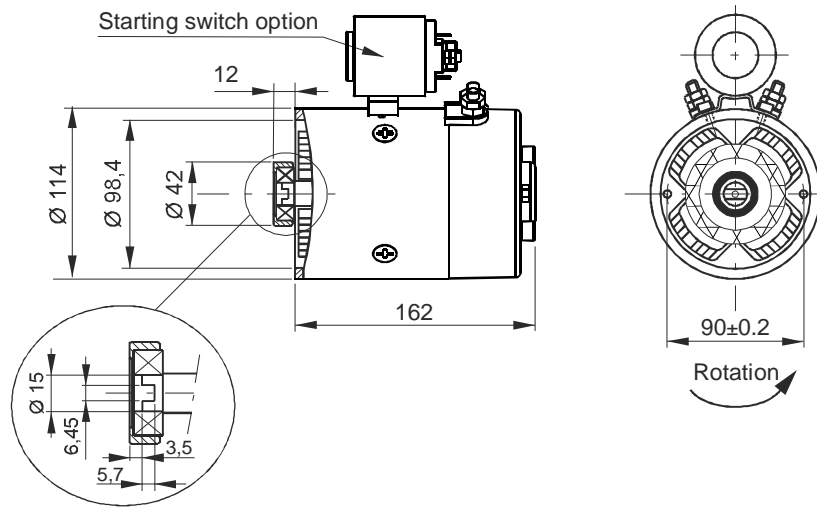

Description	PPC assembly code	Spare part code	Nominal duty cycle	Nominal speed	Nominal current
1600W 12V DC + thermal protector	1,6 12DC/T	M46C1ST16	S2: 2 min S3: 12% ED	2600 rpm	230 A
2100W 12V DC + thermal protector	2,1 12DC/T	M46C1ST21	S2: 1,2 min S3: 7,5% ED	2300 rpm	330 A
2200W 24V DC + thermal protector	2,2 24DC/T	M46C2ST22	S2: 2 min S3: 12% ED	2600 rpm	140 A

Options & couplings

Description	PPC assembly code	Spare part code
12V DC 150 Amp start switch + mounting kit	S150 12DC 112	M47SC0001 + M47SK1121
24V DC 150 Amp start switch + mounting kit	S150 24DC 112	M47SC0002 + M47SK1121
Remote wired control with 2 buttons and 3m cable	P0201 (single acting)	
Remote wired control with 4 buttons and 3m cable	P0202 (double acting)	
DC motor plastic cover	F16000001	
Coupling for Ø114 motors - Ø125 DC motors and gr.1 pump	E36200001	
Coupling for Ø114 motors and gr.0 pump	E36200005	

Notes: the starting switch mounting kit is provided when specifying the /S150 as motor option in PPC assembly code. When ordering spare starting switches, it must be ordered separately (code: M47SK1121).

The coupling is already included when specifying the motor in PPC assembly code. It is to be indicated only when ordering PPC with no motor but with coupling.

Motor plastic cover F16000001

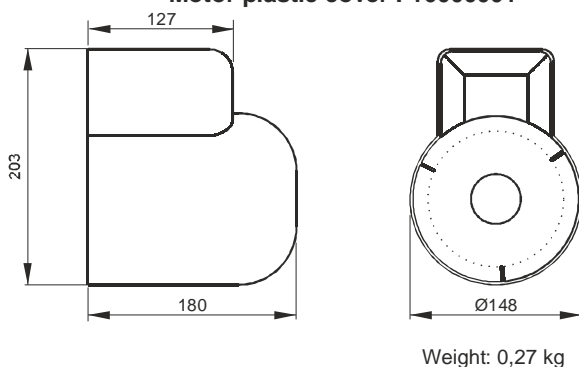

Coupling E36200005

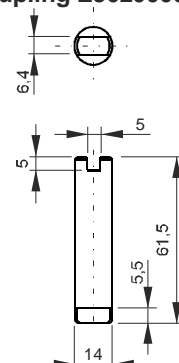

Coupling E36200001

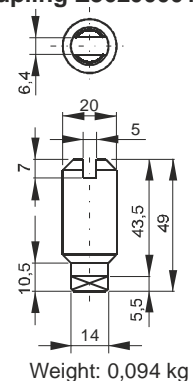

FAN COOLED INTEGRAL DC MOTORS Ø 125



Compound wound
Protection degree: IP20
Insulation class: F
Weight: 11kg

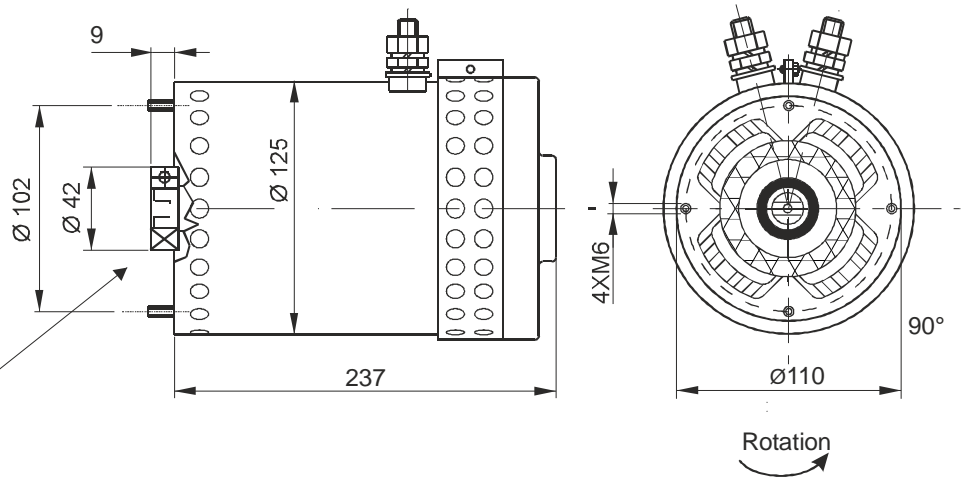
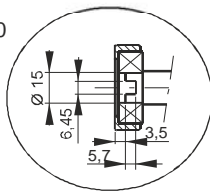

Code

Description	PPC assembly code	Spare part code	Nominal duty cycle	Nominal speed	Nominal current
2400W 12V DC motor with thermal protection & fan	2,4 12DC/T	M46C1ST24	S2: 4min S3: 7,5% ED	3400 rpm	290 A
3000W 24 V DC motor with thermal protection & fan	3 24DC/T	M46C2ST30	S2: 4min S3: 7,5% ED	3500 rpm	170 A

Options & couplings

Description	PPC assembly code	Spare part code
12V DC 200 Amp start switch + mounting kit	S200 12DC	M47SC0001
24V DC 150 Amp start switch + mounting kit	S00 24DC	M47SC0002
Remote wired control with 2 buttons and 3m cable	P0201 (single acting)	
Remote wired control with 4 buttons and 3m cable	P0202 (double acting)	
Coupling for Ø114 motors - Ø125 DC motors and gr.1 pump	E36200001	

The coupling is already included when specifying the motor in PPC assembly code. It is to be indicated only when ordering PPC with no motor but with coupling.

Coupling E36200001

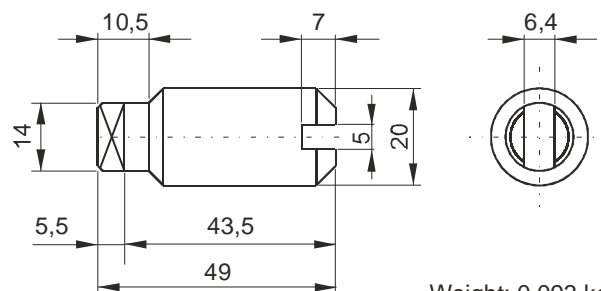

Weight: 0,093 kg

HEAVY DUTY DC MOTORS Ø 151 WITH FAN COOLING



Series wound
 Protection degree: IP20
 Insulation class: F
 Weight: 21,5 kg

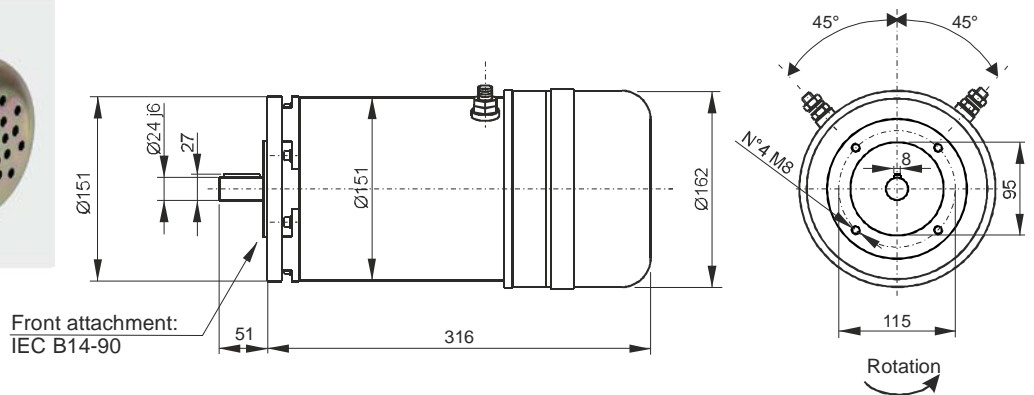

Code

Description	PPC code	Spare part code	Nominal duty cycle	Nominal speed	Nominal current	Mounting kit
2500W 12V DC motor + thermal protection & fan	2,5HD 12DC/T	MB14C1ST25	S2: 16min	1700 rpm	290 A	XB1490
3000W 24V DC motor + thermal protection & fan	3HD 24DC/T	MB14C2ST30	S2: 16min	1700 rpm	170 A	XB1490
4000W 24V DC motor + thermal protection & fan	4HD 24DC/T	MB14C2ST40	S2: 10min	2000 rpm	240 A	XB1490

Options

Description	PPC assembly code	Spare part code
Starting switch 200A 12 or 24V DC	S200 12DC S200 24DC	M47ZC0001 (12 V DC) M47ZC0002 (24 V DC)
Remote wired control with two/four buttons and 3m cable	P0201 P0202	P0201 (single acting) P0202 (double acting)

The mounting kit is already included when specifying the motor in PPC assembly code. When ordering spare part motors, the mounting kit must be ordered separately.

Other B14 DC motors for heavy duty or special applications

They are available with Ø125, Ø151 or Ø191 in multiple executions, engineered to perform heavy duty cycles and tailor made to suit each specific application, with or without fan cooling or thermal protection. They are mounted on the central manifold with B14 standard mounting kits.

To properly choose these motors, following minimum information must be provided: 1) motor power and voltage, 2) application type, 3) duty factors: S2 [min] - continuous running time and S3 [%] - percentage of running time on total cycle time, 4) required motor speed, 5) quantity to be supplied.

Some examples:

Cod. MB14M1S010: 1000W 12V DC frame 80 B14 motor

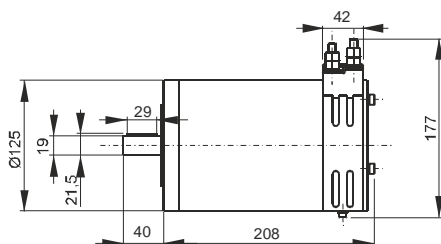

Cod. MB14M2S020: 2000W 24V DC frame 80 B14 motor

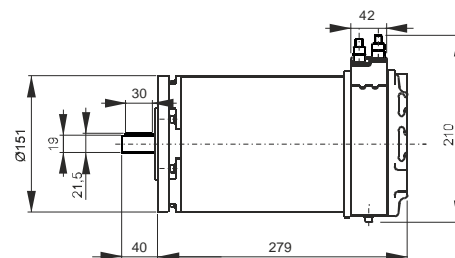

DC MOTORS OPTIONS



Remote control P0201
for one single or double acting cylinder

Weight: 0,58 kg
Protection degree: IP65

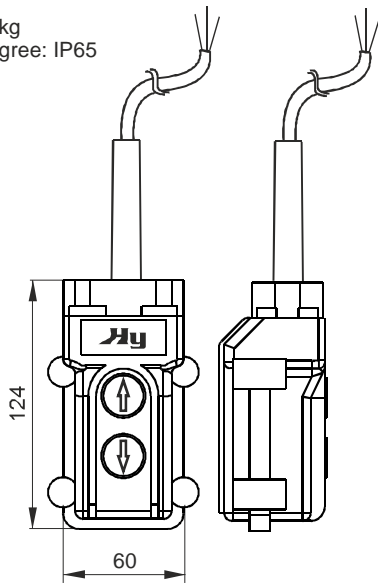

Spare part code
P0201



Remote control P0202
for two double acting cylinders

Weight: 0,60 kg
Protection degree: IP65

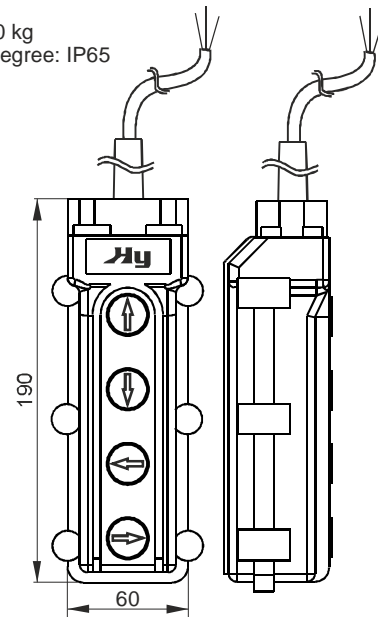

Spare part code
P0202

Electric connection schemes

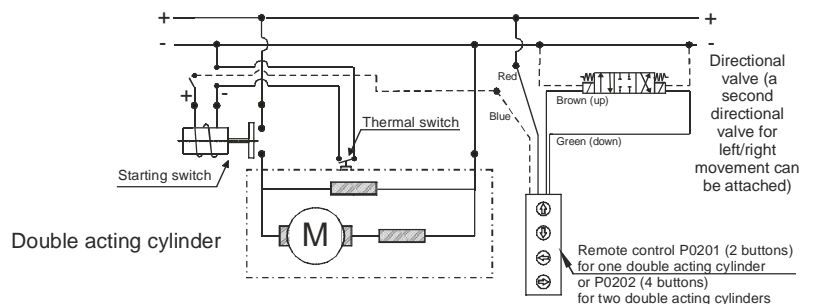
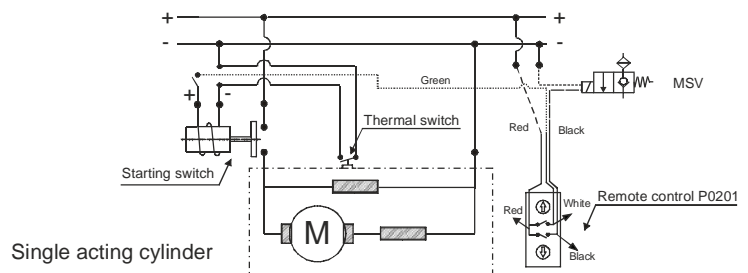
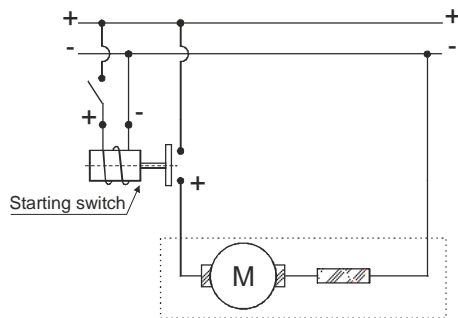

DC MOTORS CHOICE AND ELECTRIC CONNECTION SCHEMES

DC motors choice

Once required pressure and flow and available voltage (12 or 24V DC) are known, you can select the motor checking on each provided diagram if a pump displacement is available at the intersection of pressure and flow values. On the relevant "I" curve you obtain the absorbed current. When the intersection point is not exactly on a pump curve, choose the closer pump.

On the right hand diagram, from the current value, you can easily obtain the maximum allowed S2 (min) and S3 (%) values. S2 gives the allowable motor continuous running time in minutes, S3 gives the allowable running time in % of the total cycle.

If obtained S2 and S3 values are not enough for required duty cycle, choose a bigger motor and repeat the calculation on the new motor curves.

Example:

For our application we have following data:

flow = 3 l/min, max pressure = 100 bar, not clearly defined duty cycle.

-We check on 1,6 Kw 12V DC motor diagram and see there is a pump available.

-We choose from curves 1,3 pump: a 1,3 cm³/rev pump. On the corresponding "I" curve we read 125 A absorbed current. In these conditions on the S2 / S3 diagram we read that the DC motor can work for maximum 7 min (S2), that is 17% (S3) of the total cycle, i.e. after 7 min working, the motor should cool down for at least 34 min.

-The total cycle time is calculated adding the working time and the idle time (17% working time plus 83% idle time), in this case 41 min. If this duty cycle is not adequate for our application, we must choose a higher power DC motor and check the relevant diagram again.

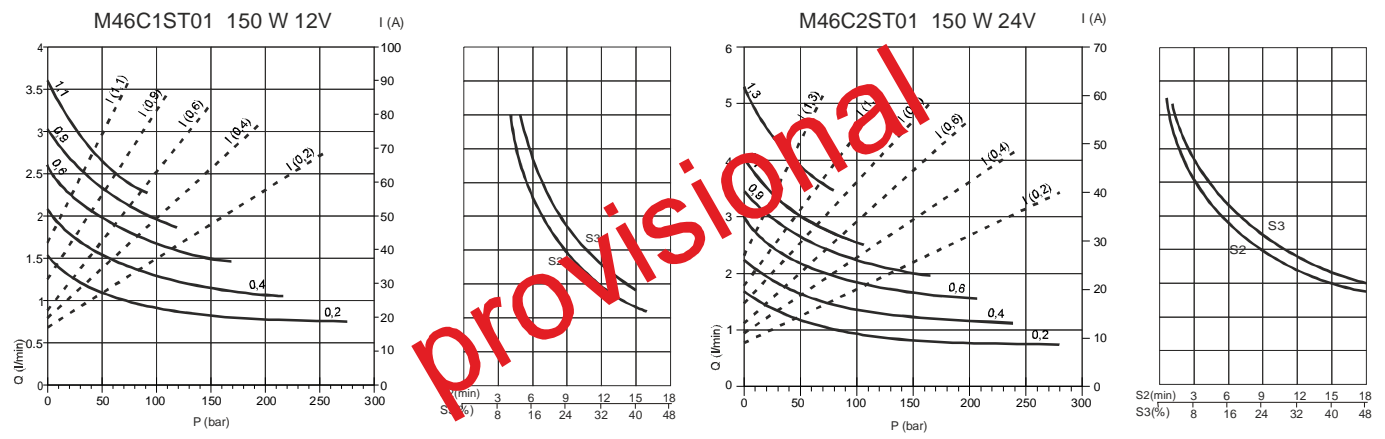
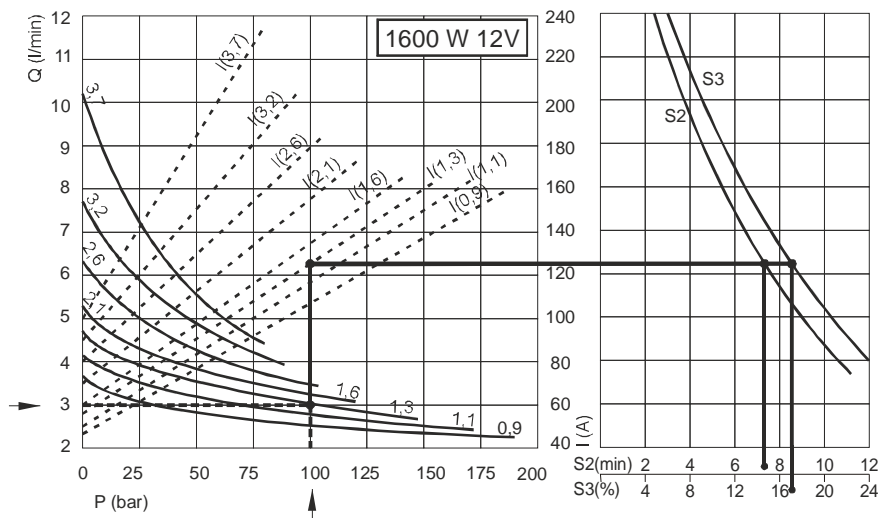

Tests made with rectified current supplied at nominal motor voltage (measured at the motor connection terminals) and oil ISO VG46 at 40°C

DC MOTORS DIAGRAMS

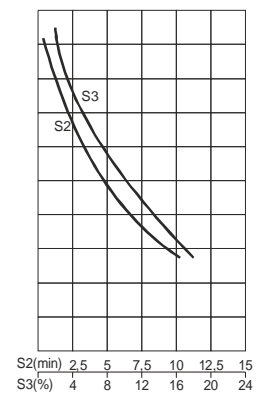
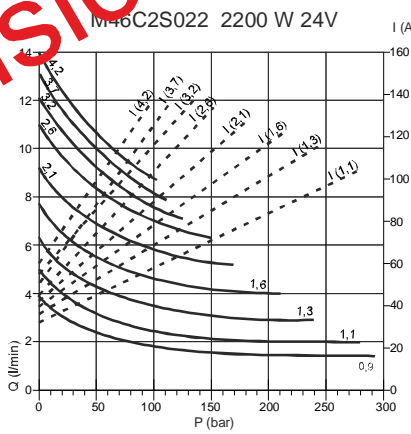
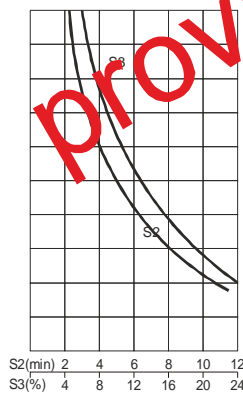
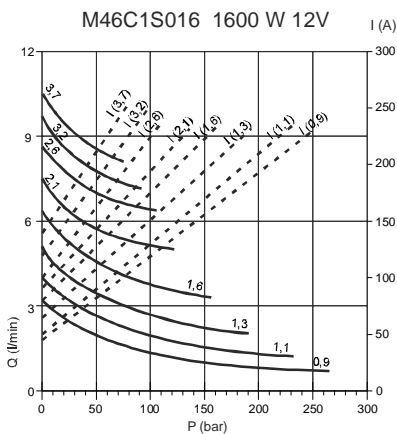
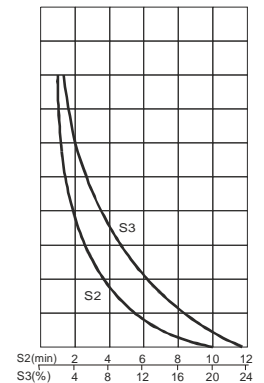
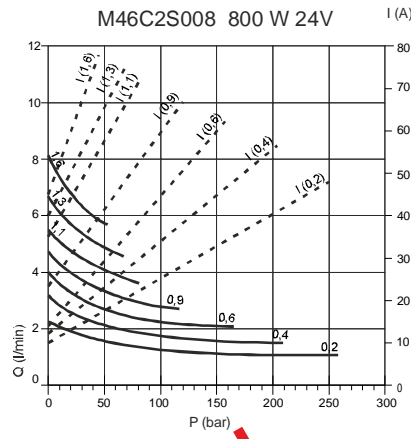
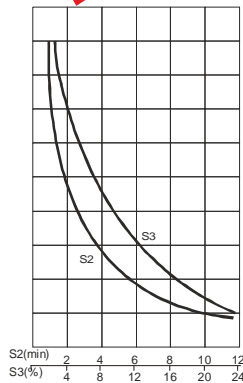
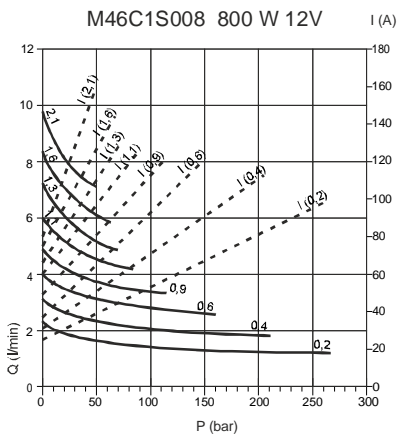
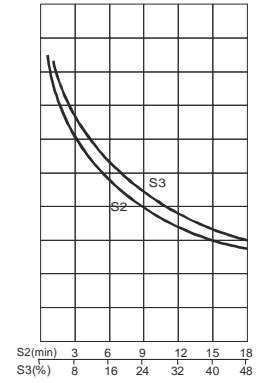
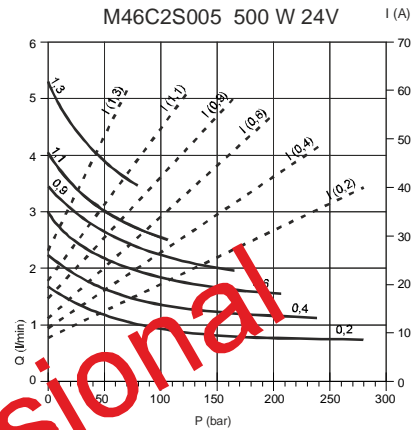
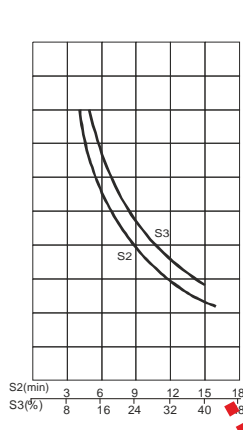
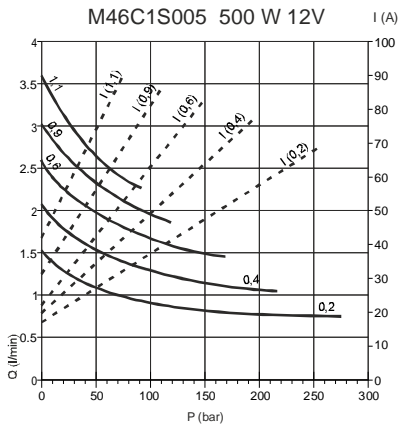

Tests made with rectified current supplied at nominal motor voltage (measured at the motor connection terminals) and oil ISO VG46 at 35°C

DC MOTORS DIAGRAMS

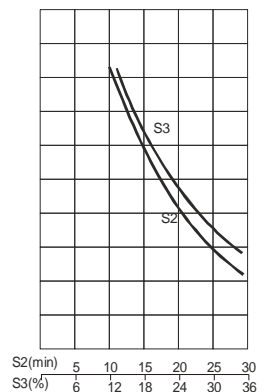
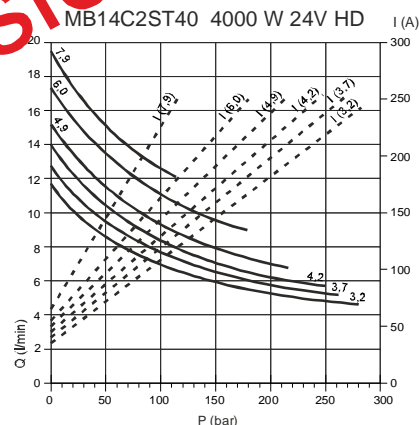
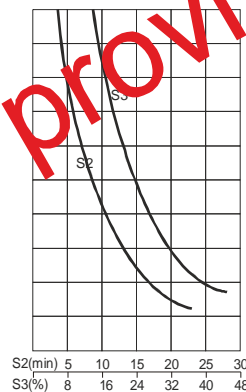
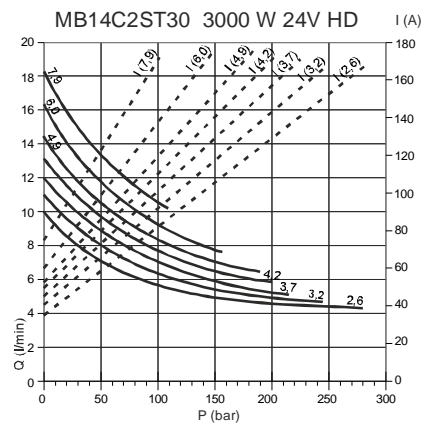
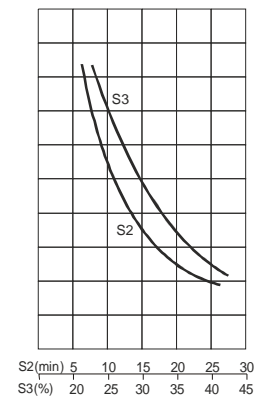
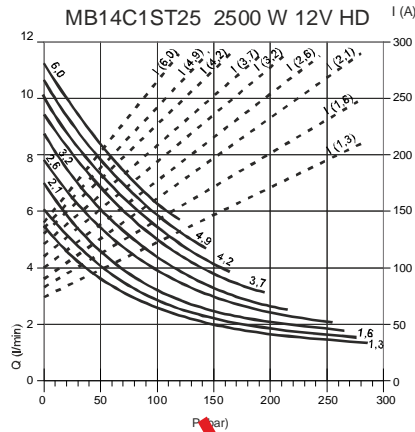
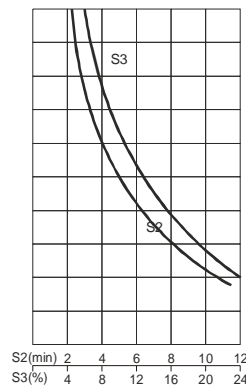
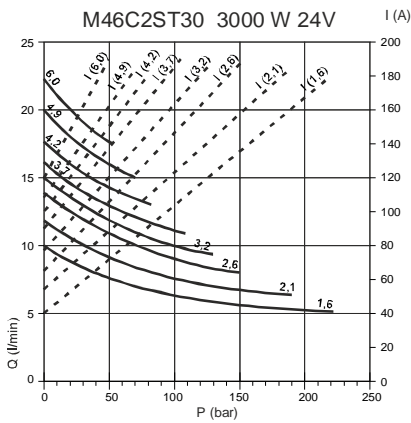
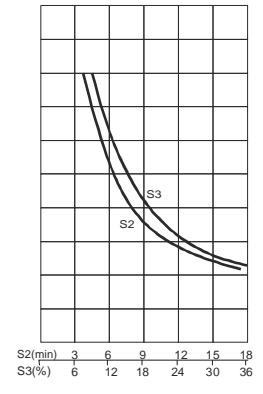
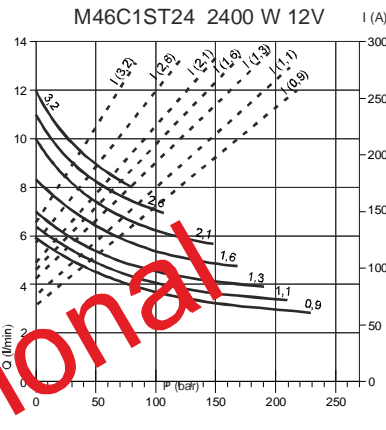
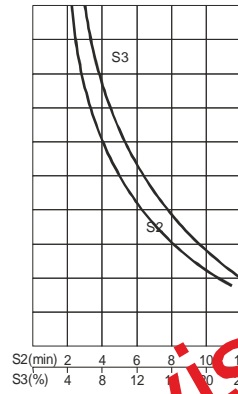
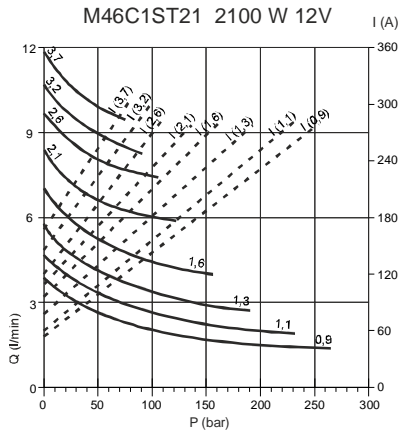

Tests made with rectified current supplied at nominal motor voltage (measured at the motor connection terminals) and oil ISO VG46 at 35°C

INTEGRAL AC MOTORS



Integral motors: single phase or three phase in frame 71, 80 and 90, with square flange for direct connection to PPC central manifold and tang drive shaft. A single coupling fits all dimensions. High starting torque single phase «HT» executions available.



Drawings show typical three phase motors. Single phase motors electric have different wiring box (including capacitors).

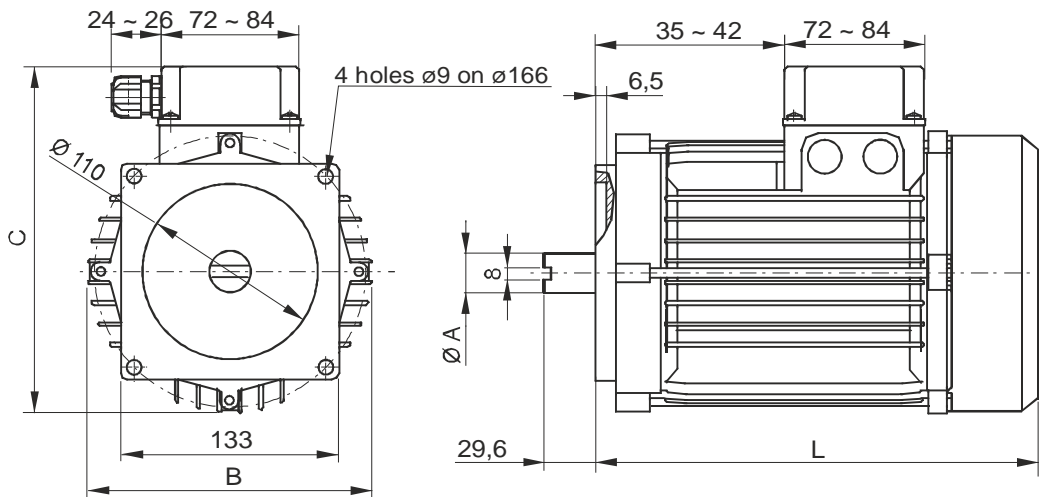

Protection degree: IP54
Insulation class: F

PPC motor assembly code

E	AC integral motor
150	Maximum Power [kW] i.e. 150 = 1,5kW
AC	Alternate current
3	Phase: 3 = three phase S = single phase
4	Poles: 4 = four poles 2 = two poles
3	Frame size: 1 = 71 2 = 80 3 = 90
S3	Type of Duty: S3 = intermittent duty HT = high torque

See a table of available codes on next table page

A single coupling can be applied on all motor frame sizes. This is the same coupling (pump side) included in B14 motors mounting kit. The coupling is already included when specifying an integral AC motor in the PPC assembly code. When ordering spare motors, the coupling is not included and must be ordered separately.

Coupling spare part code
E36100000 for Gr.1 pumps

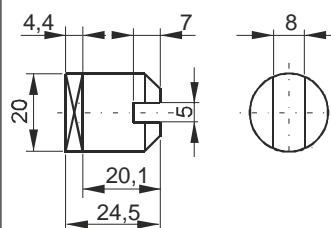

Weight: 0,046 Kg

Coupling spare part code
E36100006 for Gr.0 pumps

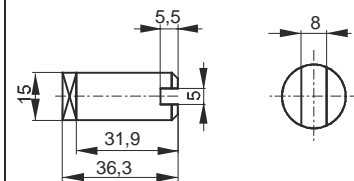

Weight: 0,040 kg

INTEGRAL AC MOTORS

Three-phase 4 poles (~1450 rpm at 50Hz)

Frame size	Maximum Power (S3 40%)	Spare motor code	Ø A	B	C	L	Weight kg
71	0,37kW (0,5HP)	E037AC341S3	17	138	180	210	5,5
	0,55kW (0,75HP)	E055AC341S3	17	138	180	210	5,5
	0,75kW (1HP)	E075AC341S3	17	138	180	210	5,6
80	0,75kW (1HP)	E075AC342S3	19	156	202	234	10
	1,1kW (1,5HP)	E110AC342S3	19	156	202	234	10,5
90	1,5kW (2HP)	E150AC343S3	24	176	217	279	14
	2,2kW (3HP)	E220AC343S3	24	176	217	279	15
	3kW (4HP)	E300AC343S3	24	176	217	279	16

Three-phase 2 poles (~2900 rpm at 50Hz)

Frame size	Maximum Power (S3 40%)	Spare motor code	Ø A	B	C	L	Weight kg
71	0,55kW (0,75HP)	E055AC321S3	17	138	180	210	5
	0,75kW (1HP)	E075AC321S3	17	138	180	210	5
80	1,1kW (1,5HP)	E110AC322S3	19	156	202	234	10
	1,5kW (2HP)	E150AC322S3	19	156	202	234	11
	2,2kW (3HP)	E220AC322S3	19	156	202	234	12
90	3kW (4HP)	E300AC323S3	24	176	217	279	16
	4kW (5HP)	E400AC323S3	24	176	217	279	16

Single-phase 4 poles (~1450 rpm at 50Hz)

Frame size	Maximum Power (S3 40%)	Spare motor code	Ø A	B	C	L	Weight kg
71	0,37kW (0,5HP)	E037ACS41S3	17	138	180	210	6,5
	0,55kW (0,75HP)	E055ACS41S3	17	138	180	210	7,2
80	0,55kW (0,75HP)	E055ACS42S3*	19	156	202	234	8
	0,75kW (1HP)	E075ACS42S3*	19	156	202	234	10
90	1,1kW (1,5HP)	E110ACS43S3*	24	176	217	279	13
	1,5kW (2HP)	E150ACS43S3*	24	176	217	279	15
	2,2kW (3HP)	E220ACS43S3*	24	176	217	279	15,5

Single-phase 2 poles (~2900 rpm at 50Hz)

Frame size	Maximum Power (S3 40%)	Spare motor code	Ø A	B	C	L	Weight kg
71	0,55kW (0,75HP)	E055ACS21S3	17	138	180	210	6
	0,75kW (1HP)	E075ACS21S3	17	138	180	210	6,5
80	0,75kW (1HP)	E075ACS22S3	19	156	202	234	8
	1,1kW (1,5HP)	E110ACS22S3	19	156	202	234	10
	1,5kW (2HP)	E150ACS22S3	19	156	202	234	11
90	1,5kW (2HP)	E150ACS23S3	24	176	217	279	12
	2,2kW (3HP)	E220ACS23S3	24	176	217	279	15

Other power / frame sizes and special motor types are available on request. Standard motors are for intermittent duty: **S3 40%** duty cycle means up to 6 switching on and off in an hour, i.e. the motors is ON for 4 min. and OFF for 6 min. They can be used in emergency situations continuously at a reduced rated power (30% less than S3 nominal power). «HT» option: available for motor spare codes marked with *.

B14 IEC AC MOTORS



B14 IEC motors: for market compatibility, any IEC standard B14 AC motor with frame 71, 80, 90 or 100/112 can be mounted. In this case two-pieces couplings and additional adaptor flanges as per next pages tables A120, A130, A140, A150 must be mounted.

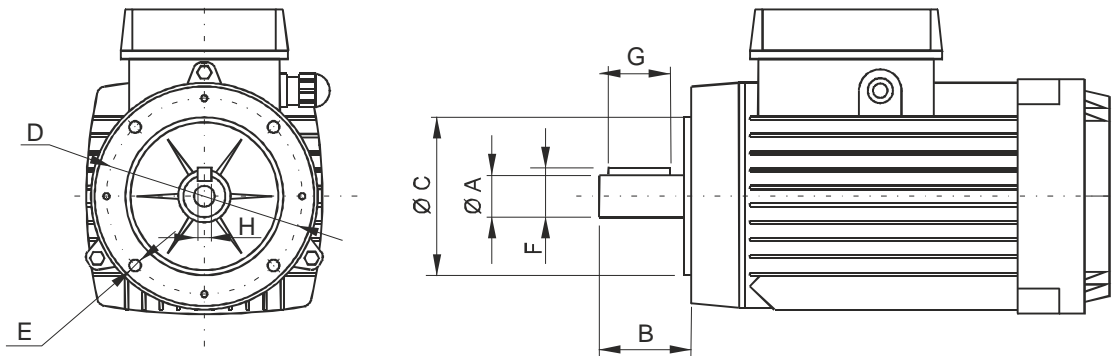

Motors overall dimensions are not indicated since they can vary substantially depending on the motor brand

B14 standard dimensions

MOTOR FRAME SIZE	Typically power range	ØA	B	ØC	D	E	F	G	H	Mounting kit
71	0,25 ~ 0,37 kW 0,37 ~ 0,5 HP	14 j6	30	70	85	M6	16	30	5	XB1471
80	0,55 ~ 0,75 kW 0,75 ~ 1 HP	19 j6	40	80	100	M6	21,5	40	6	XB1480
90	1,1 ~ 1,5 kW 1,5 ~ 2 HP	24 j6	50	95	115	M8	27	50	8	XB1490
100/112	2,2 ~ 7,5 kW 3 ~ 10 HP	28 j6	60	110	130	M8	31	60	8	XB14100

PPC B14 motor assembly code

7,5	Power [kW]
AC	Alternate current
3	Phase: 3 = three phase S = single phase
4	Poles: 4 = four poles 2 = two poles
5	Frame size: 1 = 71 2 = 80 3 = 90 4 = 100 5 = 112
-	Duty factor: - = ED 100% (S1) S3 = intermittent duty

Mounting kits spare parts

The B14 mounting kits are made of:
 - a semi-coupling E36100000 (the same used for integral AC motors) on pump shaft side
 - a semi-coupling on motor shaft side, which is different for any frame size
 - an adaptor flange to suit the central manifold, which is also different for any frame size.

The mounting kit is already included when specifying a B14 AC motor in PPC assembly code. When ordering spare motors, the relevant mounting kit is not included and must be ordered separately.

MOUNTING KIT FOR FRAME 71 B14 IEC MOTORS



Kit weight: 0,32 Kg

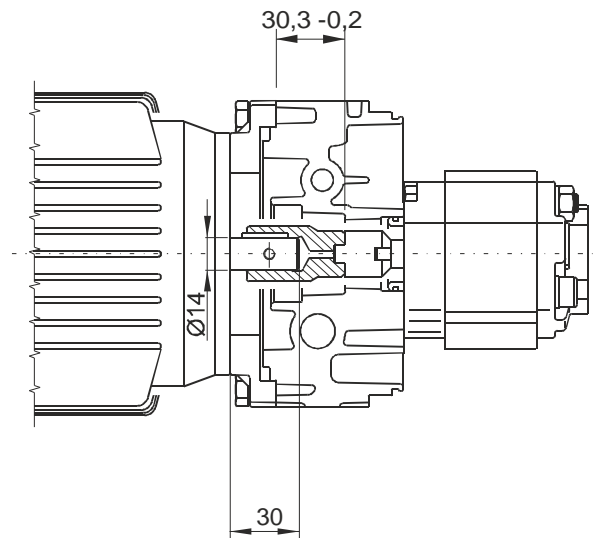

Adaptor flange

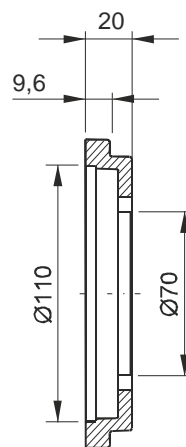
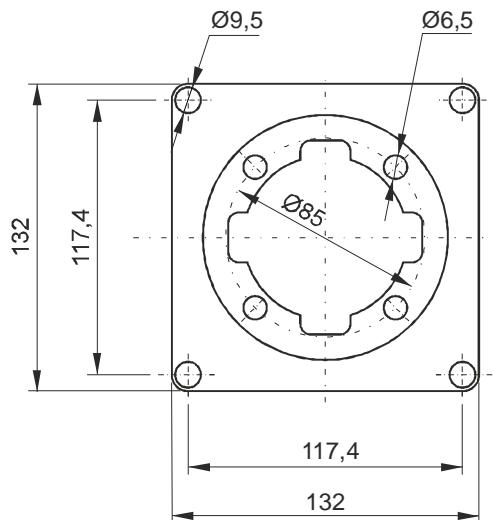

Weight: 0,18 Kg

Coupling

Pump group 1 side **E36100000**

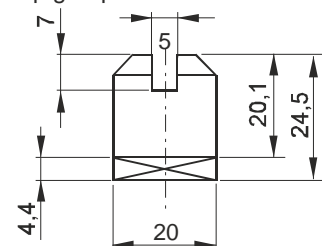

Pump group 0 side **E36100006**

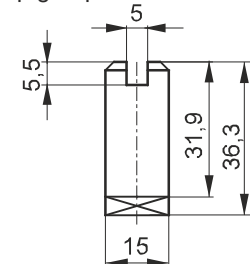

Motor side

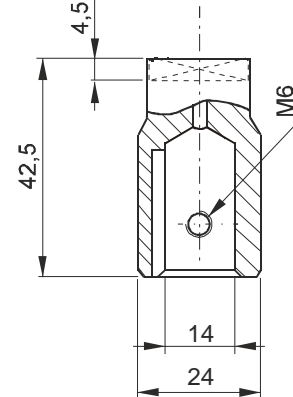

Description	PPC assembly code*	Spare part code
B14 71 motor side semi-coupling	XB1471 -0 (gr.0) -1 (gr.1)	E36100001
B14 pump side semi-coupling		E36100006 E36100000
B14 71 adaptor flange		F27010001

* Note: the coupling+ flange kit is already included when specifying a B14 motor in PPC assembly code. XB14-71 code to be indicated only when ordering PPC with no motor but with coupling + flange kit.

Attention! When assembling frame 71 B14 motors with X-B14 flange + couplings kit, please respect positioning tolerances as per top drawing. Failing to do so can cause malfunctioning or components failure.

MOUNTING KIT FOR FRAME 80 B14 IEC MOTORS



Kit weight: 0,36 Kg

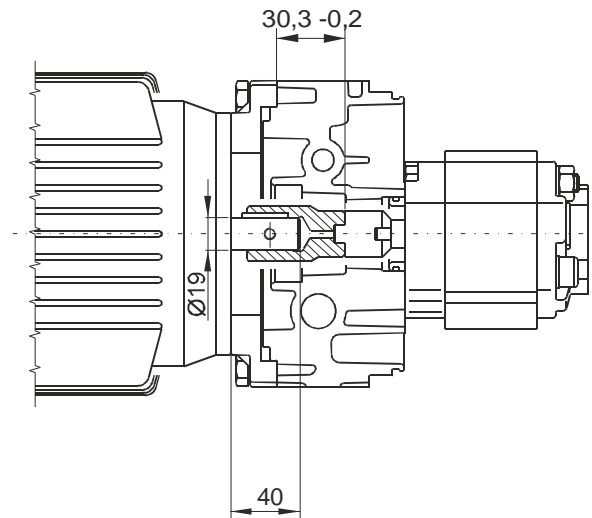

Adaptor flange

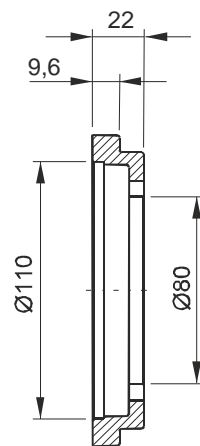
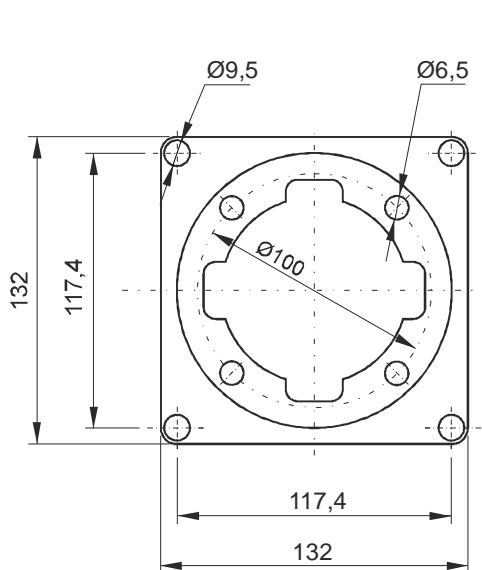

Weight: 0,21 Kg

Coupling

Pump group 1 side **E36100000**

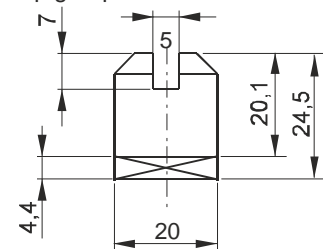

Pump group 0 side **E36100006**

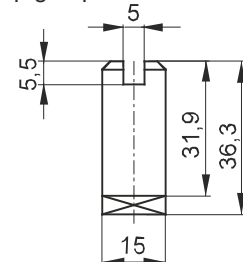

Motor side

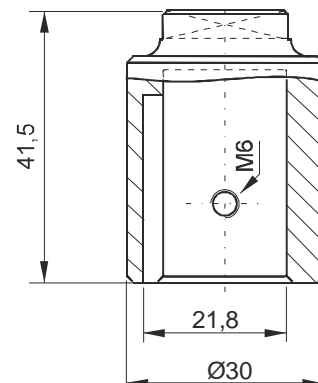

Description	PPC assembly code*	Spare part code
B14 80 motor side semi-coupling	XB1480 -0 (gr.0) -1 (gr.1)	E36100002
B14 pump side semi-coupling		E36100006 E36100000
B14 80 adaptor flange		F27010002

* Note: the coupling+ flange kit is already included when specifying a B14 motor in PPC assembly code. XB14-80 code to be indicated only when ordering PPC with no motor but with coupling + flange kit.

Attention! When assembling frame 80 B14 motors with X-B14 flange + couplings kit, please respect positioning tolerances as per top drawing. Failing to do so can cause malfunctioning or components failure.

MOUNTING KIT FOR FRAME 90 B14 IEC MOTORS



Kit weight: 0,59 Kg

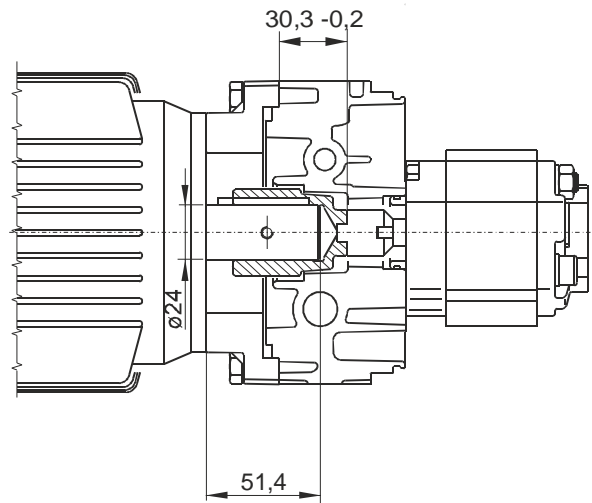

Adaptor flange

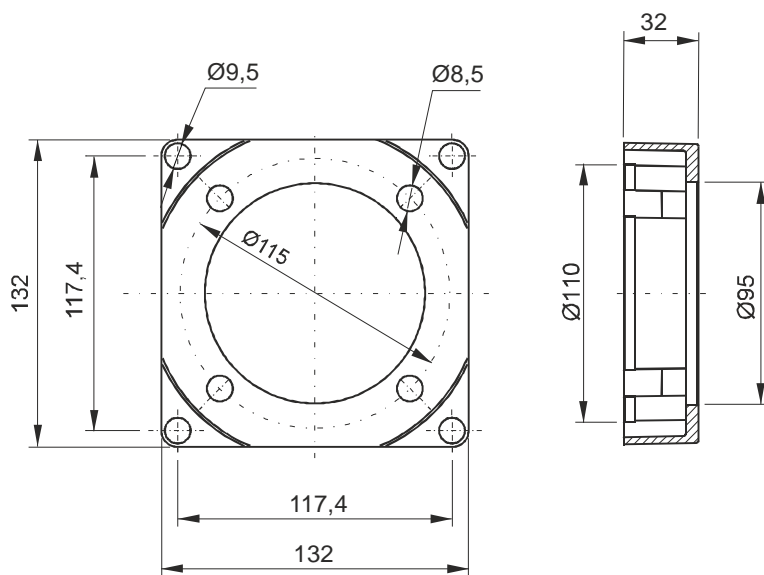

Weight: 0,35 Kg

Coupling

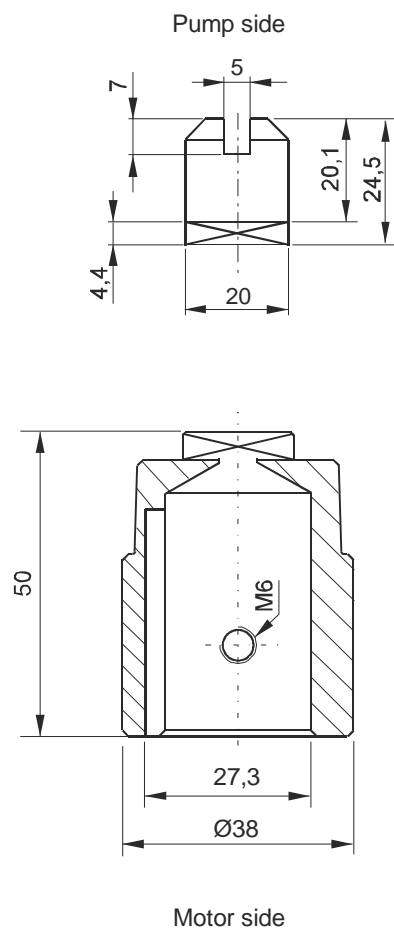

Description	PPC assembly code*	Spare part code
B14 90 motor side semi-coupling	XB1490	E36100003
B14 pump side semi-coupling		E36100000
B14 90 adaptor flange		F27010003

* Note: the coupling+ flange kit is already included when specifying a B14 motor in PPC assembly code. XB14-90 code to be indicated only when ordering PPC with no motor but with coupling + flange kit.

Attention! When assembling frame 90 B14 motors with X-B14 flange + couplings kit, please respect positioning tolerances as per top drawing. Failing to do so can cause malfunctioning or components failure.

MOUNTING KIT FOR FRAME 100/112 B14 IEC MOTORS



Kit weight: 0,99 Kg

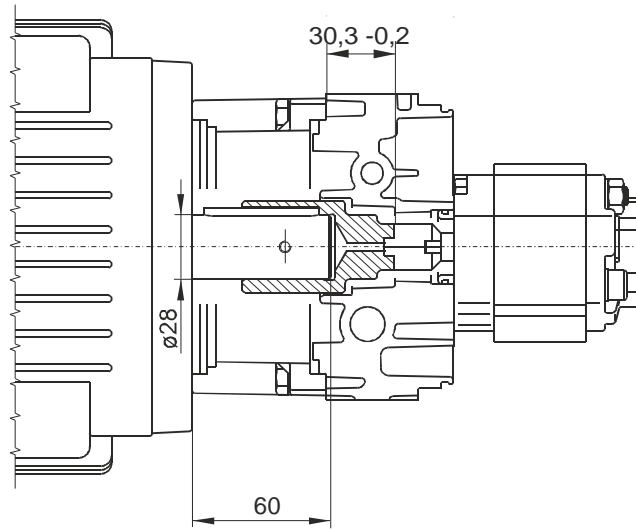

Adaptor flange

Coupling

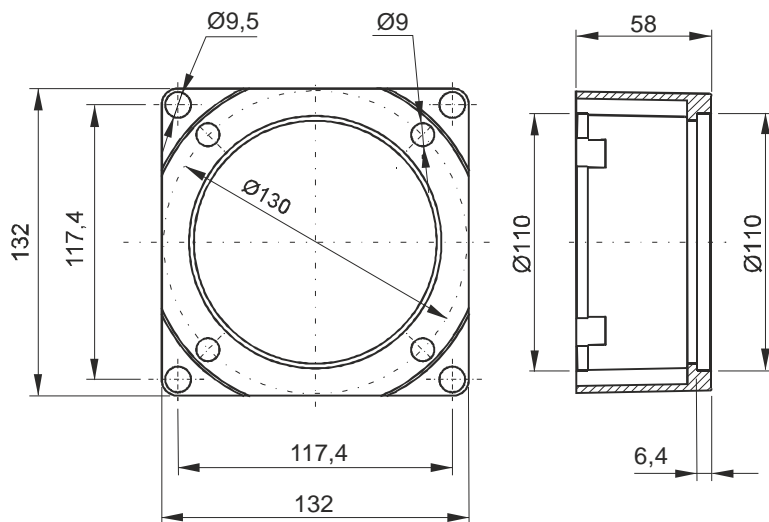

Weight: 0,66 Kg

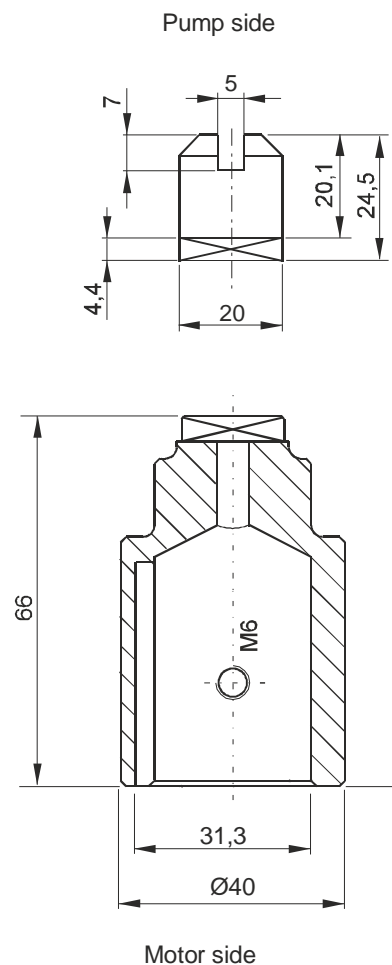

Description	PPC assembly code*	Spare part code
B14 100 motor side semi-coupling	XB14100	E36100004
B14 pump side semi-coupling		E36100000
B14 100 adaptor flange		F27010004

* Note: the coupling+ flange kit is already included when specifying a B14 motor in PPC assembly code. XB14-100 code to be indicated only when ordering PPC with no motor but with coupling + flange kit.

Attention! When assembling frame 100/112 B14 motors with X-B14 flange + couplings kit, please respect positioning tolerances as per top drawing. Failing to do so can cause malfunctioning or components failure.

NEMA 56C AC MOTORS



Nema motors: for market compatibility, any Nema 56C face standard AC motor can be mounted. These motors are normally procured by the customer itself. In this case Hydronit can supply a two-pieces coupling and additional adaptor flange as per next page table A170.

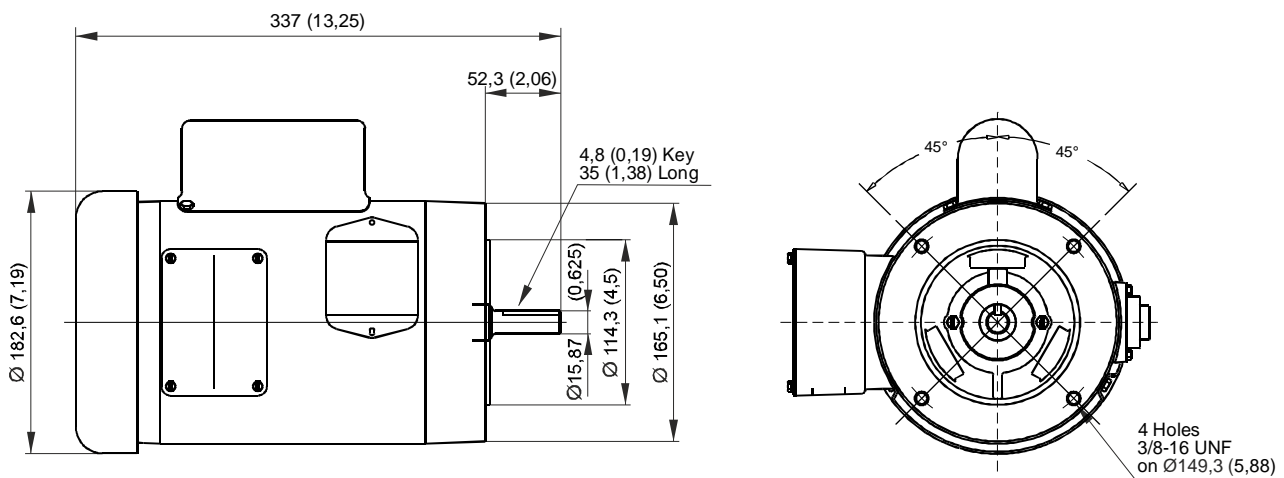

Motors overall dimensions are not indicative since they can vary substantially depending on the motor brand

Motor attachment	Typical power range	Pump group	PPC mounting kit code	Spare part code	Description
56C	0,18 ~ 1,5 kW 0,25 ~ 2,0 HP	0	XNEM-56-0	E36156C01	Nema 56C face motor side semi-coupling
				E36100006	gr.0 pump semi-coupling
				F270656C01	Nema 56C face adaptor flange
		1	XNEM-56-1	E36156C01	Nema 56C face motor side semi-coupling
				E36100000	gr.1 pump semi-coupling
				F270656C01	Nema 56C face adaptor flange

MOUNTING KIT FOR NEMA 56C AC MOTORS



Kit weight: 0,54 (1,2 lbs)

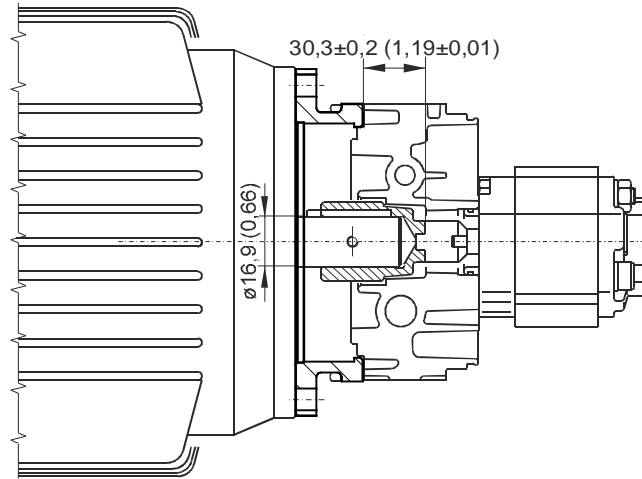

Adaptor flange

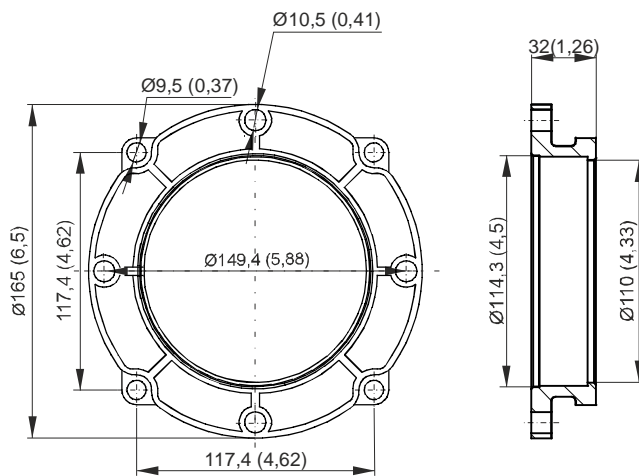

Weight: 0,35kg (0,77 lbs)

Coupling

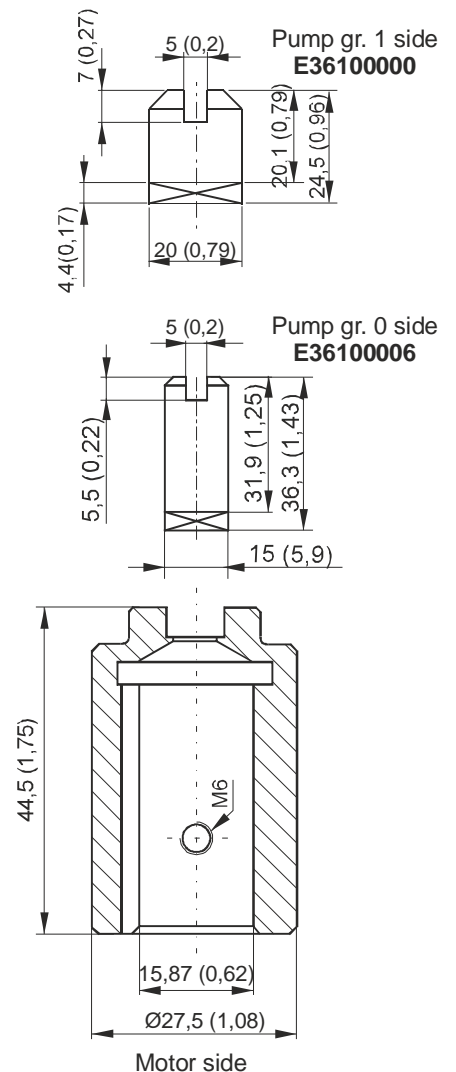

Description	PPC assembly code*	Spare part code
Nema 56C motor side semi-coupling	X56-0 (gr.0 pumps) -1 (gr.1 pumps)	E36156C01
Nema 56C pump side semi-coupling		E36100006 E36100000
Nema 56C 90 adaptor flange		F27056C01

* Note: the coupling+ flange kit is already included when specifying a Nema 56C motor in PPC assembly code. Nema 56C code to be indicated only when ordering PPC with no motor but with coupling + flange kit.

Attention! When assembling Nema 56C-face motors with XB56C-1 flange + couplings kit, please respect positioning tolerances as per top drawing. Failing to do so can cause malfunctioning or components failure.

UNIVERSAL CENTRAL MANIFOLD

A single universal die-cast aluminium central manifold in 4 different executions is the core part to realize all power units in industrial, mobile and marine fields. It features the highest integration and flexibility on the market, with up to nine devices which can be fitted inside, plus a wide selection of manifold blocks which can be connected externally to suit spool or cartridge type valves

The interface to hose fittings or external additional manifolds is unified. The P and T ports threads for the hose fittings direct connection are 1/4" BSPP (International standard) or 9/16-18UNF (SAE06) for the American standard execution.

The interfaces to tanks and motors are unified. All plastic or steel tanks have same interface and can be easily swapped. All AC or DC motors can be fitted easily either directly to the central manifold or through adaptor flanges (B14 IEC standard motors)

Lateral cavities are according SAE08 standard (3/4-16UNF), except for the main relief valve one which is M20x1,5

Maximum flow is 25 l/min, with a low pressure drop, and maximum motor power is 7,5kW, well above the average of other alternative products on the market

Clockwise (our standard) or counterclockwise tang drive shaft standard gear pumps can be mounted. Double pump, also with HI-LO circuit, are available too.

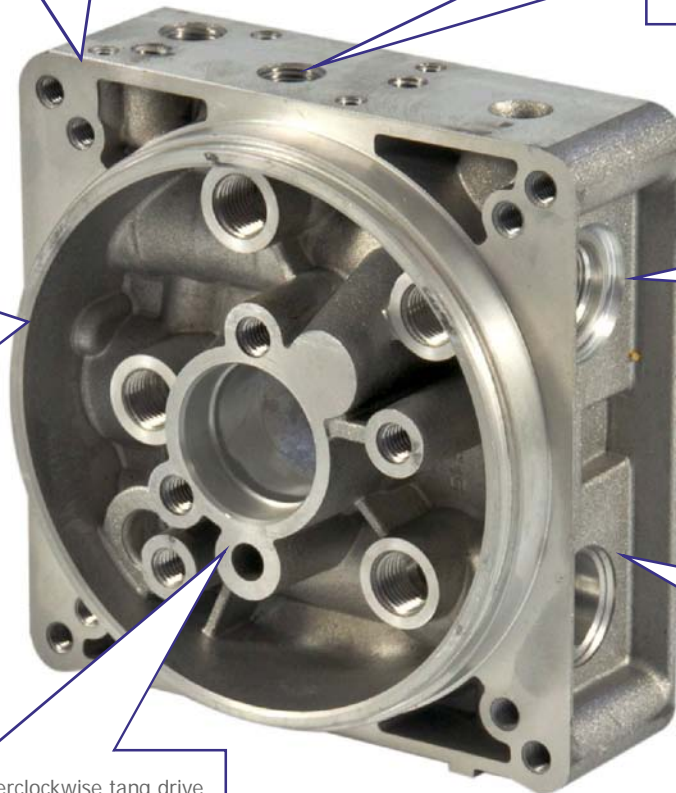

Which universal central manifold execution should I choose?

UA type is the most widely applied for single acting or double acting circuits. UB is the real «Universal» central manifold since adds to UA type features two extra lateral cavities to mount, for example, an integrated emergency hand pump and an externally adjustable flow control. U4 is recommended for compact and cost effective double acting circuits with a single cylinder while UR is for bidirectional pumps.

Do I need special tools to assemble the components within the central manifold?

No. All valves are screw-in type in a single piece construction (no loose nuts, washers,... difficult to assemble and falling apart). The components are easily assemblable with simple hand tools and hexagon keys.

Is the central manifold available as loose component?

Yes. We can supply either fully assembled and tested power packs or kits of loose components, which can be kept in stock by our worldwide distributors and easily assembled to satisfy local market demand quickly and effectively. Central manifolds and other components are 100% tested even when supplied as loose parts.

UNIVERSAL CENTRAL MANIFOLD «UA» EXECUTION VALVE COMBINATIONS

EM		CM04M
E		CM04
U		PMC02
S		CSB
Z		CPE
D		MDV30E
C		MSV31E
A		MSV30
B		MSV30E
T		CSPC15

G		E70100005
L		E70100004
P		E70100006
H		E70100003
N		E70100002
J		VUC20

J		VUC20
S		CSB

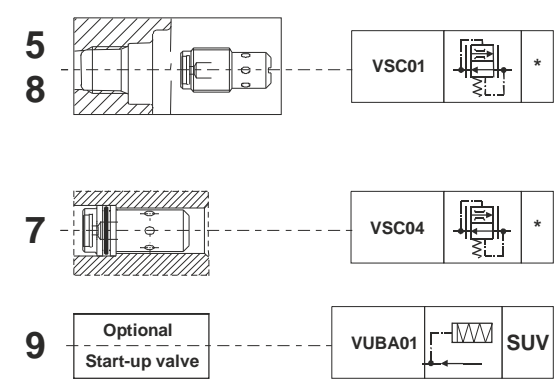
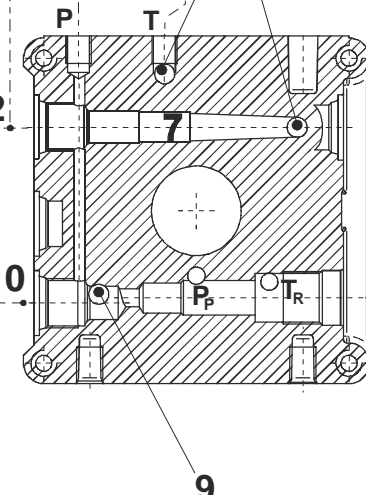
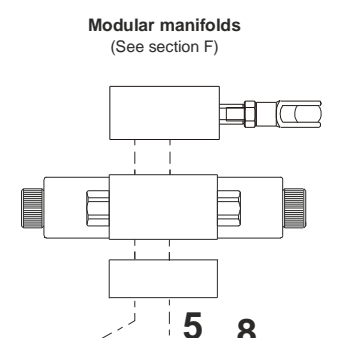
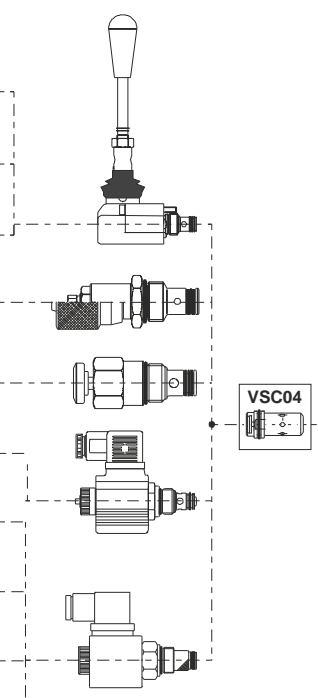

E70100010		XP
VMD35		D/*

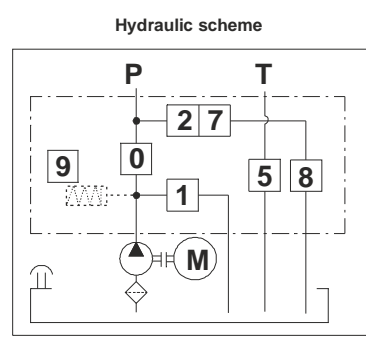

UNIVERSAL CENTRAL MANIFOLD «U4» EXECUTION VALVE COMBINATIONS

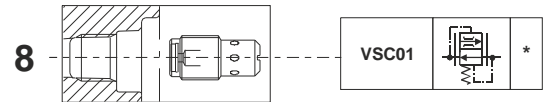

Modular manifold with check valves
(See section F)

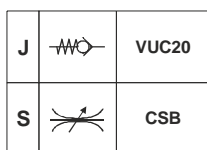
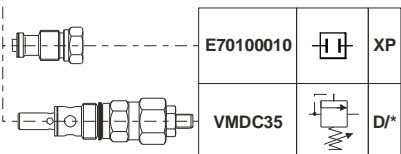
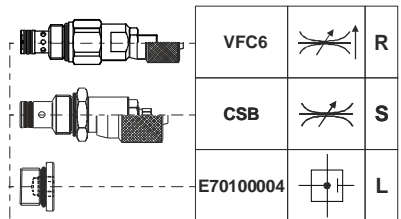
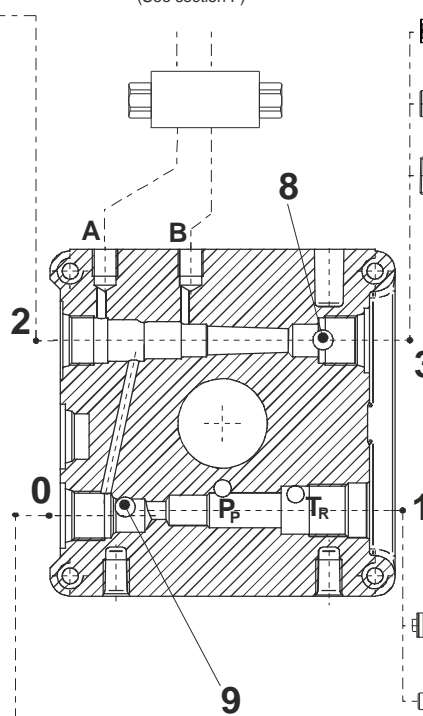

Hydraulic scheme

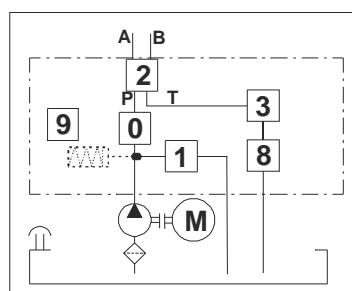

SECTION B

UNIVERSAL CENTRAL MANIFOLD «UB» AND «UR» EXECUTION VALVE COMBINATIONS

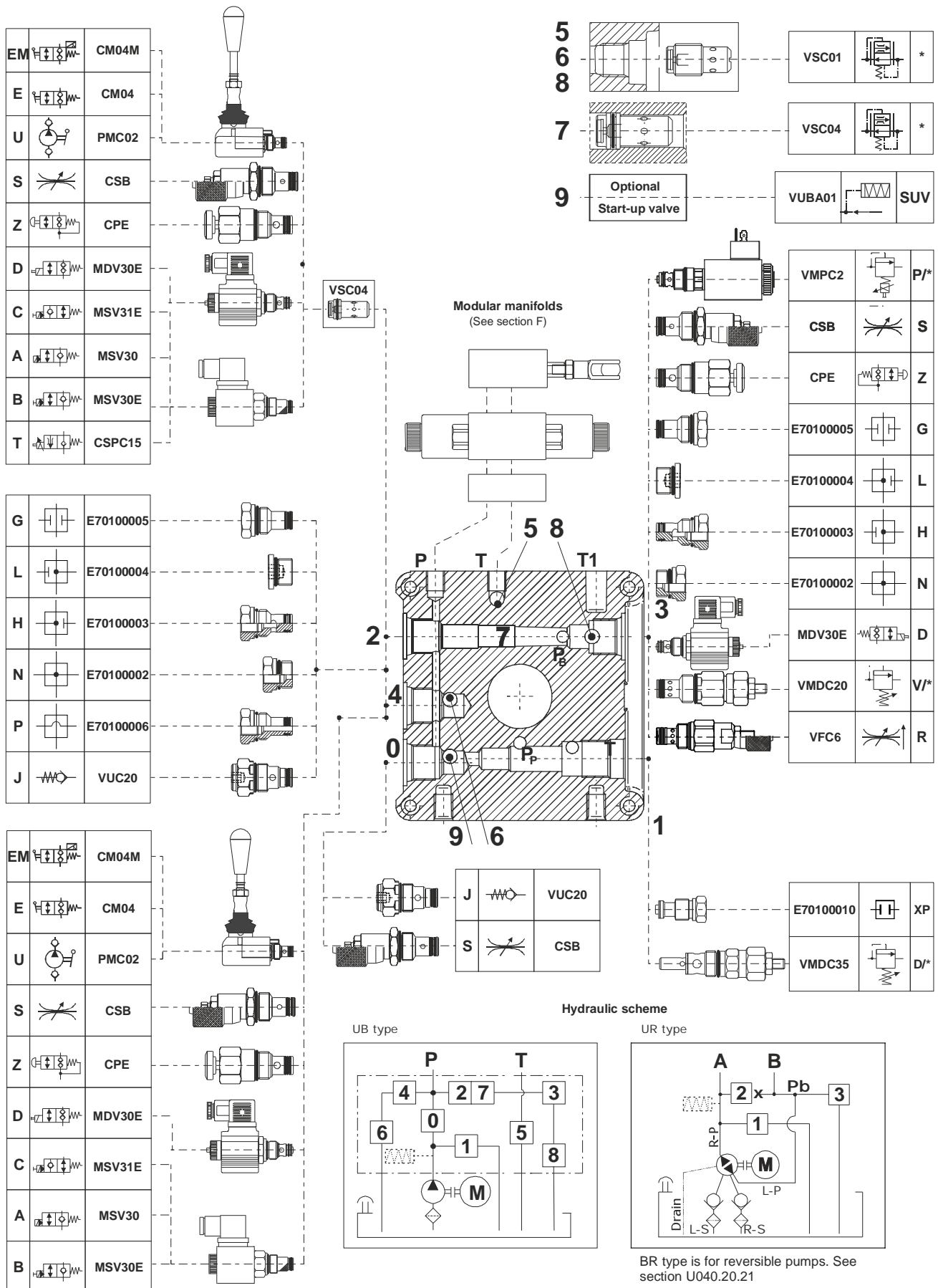

UNIVERSAL CENTRAL MANIFOLD OVERALL DIMENSIONS

Type	Spare part code
UA	E60104020
UB	E60104021
U4	E60104022
UR	E60104023
UAUS	E60104020US
UBUS	E60104021US
U4US	E60104022US
URUS	E60104023US

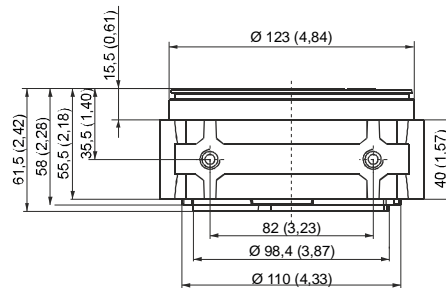

Weight: 1,1 kg (2,42 lb)

Notes:

- codes ending with US are intended for the American market and are machined with 9/16-18 UNF (SAE06) exit ports.
- all dimensions in mm + (inches)

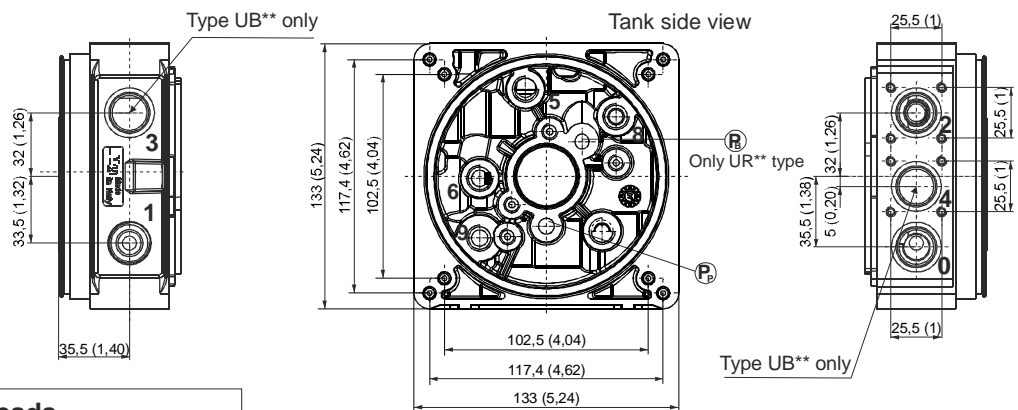

Cavity	Threads
1	M20x1,5 (relief valve)
0, 2, 3, 4	3/4-16 UNF (SAE08)
P-T	1/4" BSPP 9/16-18UNF (SAE06) US type
T ₁	1/4" BSPP (threaded on request only)
5, 6, 8, 9	1/4" BSPP (9 threaded on request only)
External manifold attachment	2 pcs M8 tie-rods 4 pcs M6 tie-rods
Tanks attachment	4 pcs M6x14
Integral AC Motors attachment	4 pcs M8x25
DC Motors attachment	2 pcs M6x14 or M6 tie rods
Pump attachments	2 pcs M8 (see pump lengths on the relevant tables)
Foot mounting support attachments	2 pcs M10x18
PMC hand pump / CM lever valve cap attachments	2 pcs M5x45

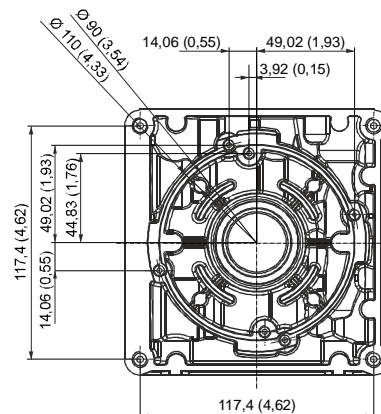
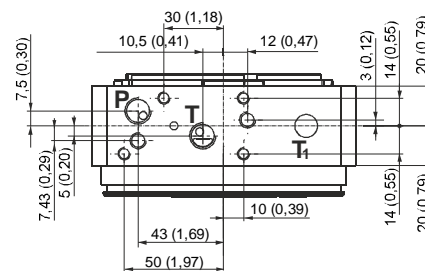

Motor side view

PUMPS

K series. The standard pressure balanced design for cost effective solutions. Also available in double execution, with or without HI-LO circuit integrated in the pump itself

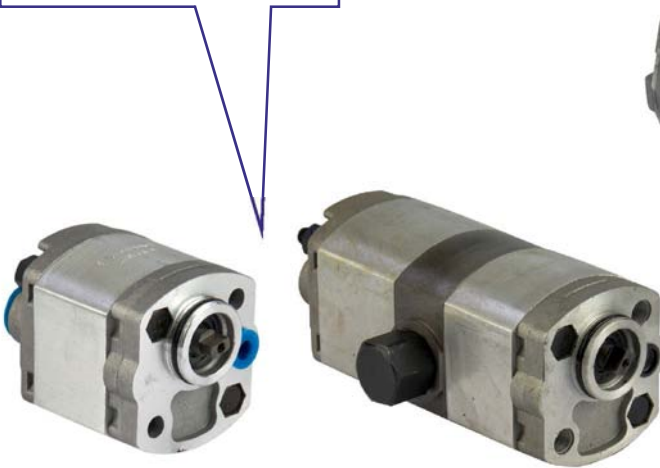

G series. The lightweight, pressure balanced, low noise and high efficiency pump specifically designed for mini power packs



H series. It features an oversized shaft and an higher number of theet for high pressure applications, up to 280 bar peak.



R series: bidirectional pumps with integrated suction check valves and two front outlet ports. They can be fitted on UR type central manifold.



Why are pressure balanced gear pumps better than fixed clearings gear pumps?

Pressure balanced gear pumps are built with lateral pressure plates which reduce the mechanical clearings on the gears with the increase of the pressure on the outlet, thus greatly improving the fluidodynamic efficiency, reducing heat generation and energy consumption. The mechanical efficiency is kept at optimal levels too.

How can we mount both group 0 and group 1 pumps on the same Universal central manifold?

The group 1 pumps fits directly on the central manifold and are fixed to it by two bolts, provided together with the pump. The group 0 pumps are fitted by the adaptor plate E60513025, which adapts the pump front flange to the central manifold.

Why are the pump technical specifications showing three maximum pressure levels?

Our pumps have three ratings for the maximum allowable pressure: 1-Peak: is the maximum one and can be allowed for a maximum cycle of 2 seconds. 2-Intermittent: it can be applied on the pump for a maximum cycle of 20 seconds; 3-Continuous: it can be applied on the pump continuously.

G TYPE GEAR PUMPS. GROUP 1

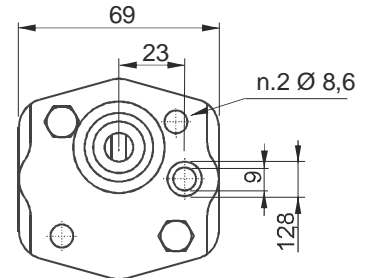
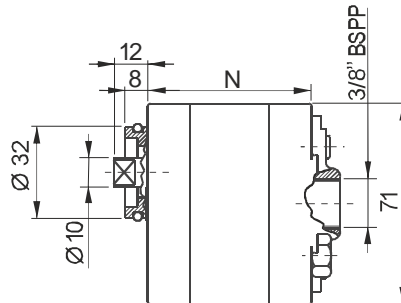

Main features

Oil temperature	-15 ÷ +80 °C
Inlet pressure	0,7 < P < 3,0 bar (absolute pressure)
Fixing bolts	2 x M8 8.8 class steel tightening torque: 25 Nm
Pressure definition	Peak pressure: cycle 2 s ON Intermittent pressure: cycle 20 s ON Continuous pressure: cycle always ON
Filtration setting	25 ÷ 50 µ

Standard rotation direction: clockwise rotation (from shaft side).
Counterclockwise rotation pumps can be mounted on request.
Ask our sales department.

Spare part code

E60 ** 30 **

Pump type:
60 = Group 1
50 = Group 0

Size:
see spare part code
on below table

PPC assembly code field

G — **Pump type:**
G = G type

1,1 — **Nominal displacement:**
(cc/rev) see below table

Available range

Nominal displacement (cc/rev)	Peak pressure (bar)	Intermittent pressure (bar)	Continuous pressure (bar)	Max speed (rpm)	N (mm)	Bolts* (mm)	Code marked on pump	Spare part code	Weight
0,8	250	230	210	6000	35,8	M8x50	EK1PD1.2G	E60603001	0,49 Kg
1,1	250	230	210	6000	36,8	M8x50	EK1PD1.6G	E60603002	0,50 Kg
1,3	250	230	210	6000	37,8	M8x50	EK1PD2G	E60603003	0,51 Kg
1,6	250	230	210	6000	38,8	M8x50	EK1PD2.5G	E60603035	0,52 Kg
2,1	250	230	210	6000	40,3	M8x55	EK1PD3.3G	E60603004	0,54 Kg
2,6	250	230	210	6000	42,3	M8x55	EK1PD4.2G	E60603005	0,56 Kg
3,2	230	210	190	5000	43,8	M8x55	EK1PD5G	E60603006	0,58 Kg
3,7	230	210	190	4500	45,8	M8x60	EK1PD5.8G	E60603007	0,61 Kg
4,2	230	210	190	4000	47,3	M8x60	EK1PD6.7G	E60603008	0,63 Kg
4,9	210	190	170	3500	49,3	M8x60	EK1PD7.5G	E60603009	0,65 Kg
6,0	210	190	170	3000	51,3	M8x90	EK1PD9.2G	E60603010	1,01 Kg
7,9	200	180	160	2100	88,0	M8x100	K1PD11.5G	E60603012	1,12 Kg
9,8	170	150	130	1700	95,0	M8x110	K1PD14.5G	E60603014	1,27 Kg

* A proper washer is to be forecast to adapt bolt length

G TYPE GEAR PUMPS. GROUP 0

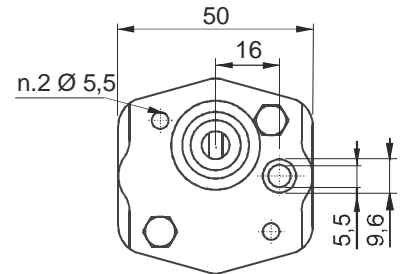
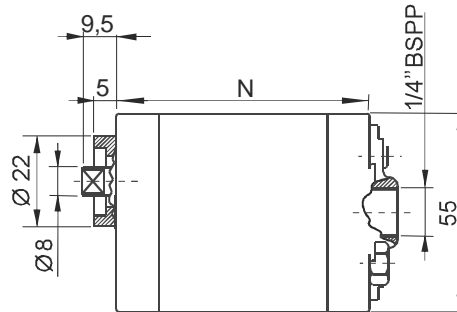

Main features

Oil temperature	-15 ÷ +80 °C
Inlet pressure	0,7 < P < 3,0 bar (absolute pressure)
Fixing bolts	2 x M8 8.8 class steel tightening torque: 25 Nm
Pressure definition	Peak pressure: cycle 2 s ON Intermittent pressure: cycle 20 s ON Continuous pressure: cycle always ON
Filtration setting	25 ÷ 50 µ

Alluminium adapter flange for group 0
Code: E60513025

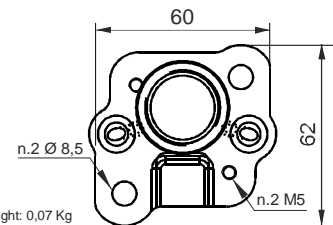

Weight: 0,07 Kg

Standard rotation direction: clockwise rotation (from shaft side).
Counterclockwise rotation pumps can be mounted on request.
Ask our sales department.

Spare part code

E60 ** 30 **

Pump type:
60 = Group 1
50 = Group 0

Size:
see spare part code
on below table

PPC assembly code field

G — **Pump type:**
G = G type

1,1 — **Nominal displacement:**
(cc/rev) see below table

Available range

Nominal displacement (cc/rev)	Peak pressure (bar)	Intermittent pressure (bar)	Continuous pressure (bar)	Max speed (rpm)	N (mm)	Bolts* (mm)	Code marked on pump	Spare part code	Weight
0,1	230	210	190	7000	44,5	M5x55	UK0,25D18G	E60503001	0,31 Kg
0,2	230	210	190	7000	44,5	M5x55	UK0,25D24G	E60503002	0,33 Kg
0,4	230	210	190	7000	47,5	M5x55	UK0,25D36G	E60503004	0,35 Kg
0,6	230	210	190	7000	51,5	M5x60	UK0,5D0.75G	E60503006	0,40 Kg

* A proper washer is to be forecast to adapt bolt length

K TYPE GEAR PUMPS. GROUP 1

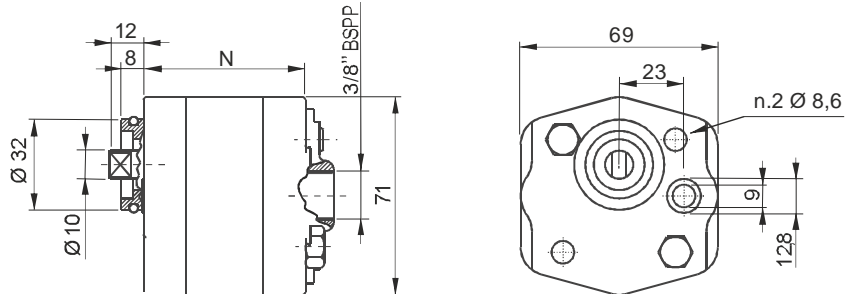

Main features

Oil temperature	-15 ÷ +80 °C
Inlet pressure	0,7 < P < 3,0 bar (absolute pressure)
Fixing bolts	2 x M8 8.8 class steel tightening torque: 25 Nm
Pressure definition	Peak pressure: cycle 2 s ON Intermittent pressure: cycle 20 s ON Continuous pressure: cycle always ON
Filtration setting	25 ÷ 50 μ

Standard rotation direction: clockwise rotation (from shaft side).
Counterclockwise rotation pumps can be mounted on request.
Ask our sales department.

Spare part code

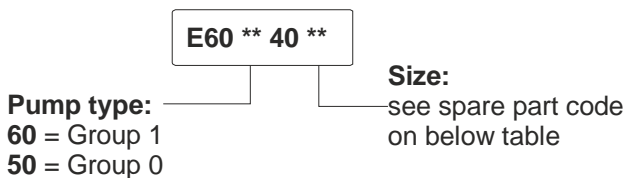

PPC assembly code field

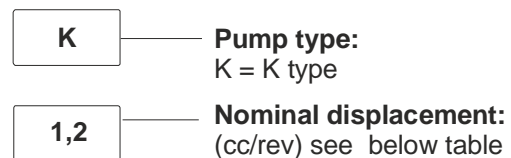

Available range

Nominal Displacement (cc/rev)	Peak pressure (bar)	Intermittent pressure (bar)	Continuous pressure (bar)	Max speed (rpm)	N (mm)	Bolts* (mm)	Spare part code	Weight
0,9	250	230	200	4500	60	M8x75	E60604001	0,73 Kg
1,2	250	230	200	4500	61	M8x75	E60604002	0,75 Kg
1,6	250	230	200	4500	63	M8x80	E60604035	0,77 Kg
2,1	250	230	200	4500	65	M8x80	E60604004	0,79 Kg
2,7	250	230	200	4500	66	M8x80	E60604005	0,82 Kg
3,2	250	230	200	4500	70	M8x85	E60604006	0,86 Kg
3,7	230	210	180	3600	72	M8x85	E60604007	0,88 Kg
4,2	230	210	180	3600	74	M8x90	E60604008	0,90 Kg
5,0	210	180	140	3000	76	M8x90	E60604009	0,94 Kg
6,0	210	180	140	3000	80	M8x100	E60604010	0,98 Kg
7,9	180	140	100	3000	90	M8x110	E60604012	1,10 Kg

Other pumps executions with different pressure/speed ratings are available on request.

* A proper washer is to be forecast to adapt bolt length

K TYPE GEAR PUMPS. GROUP 0

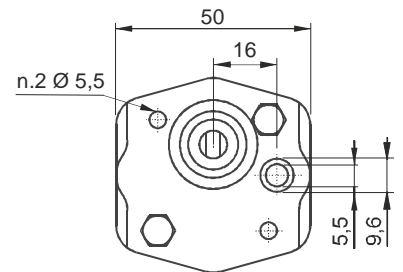
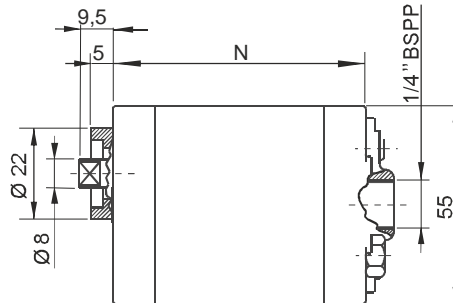

Main features

Oil temperature	-15 ÷ +80 °C
Inlet pressure	0,7 < P < 3,0 bar (absolute pressure)
Fixing bolts	2 x M8 8.8 class steel tightening torque: 25 Nm
Pressure definition	Peak pressure: cycle 2 s ON Intermittent pressure: cycle 20 s ON Continuous pressure: cycle always ON
Filtration setting	25 ÷ 50 µ

Alluminium adapter flange for group 0
Code: E60513025

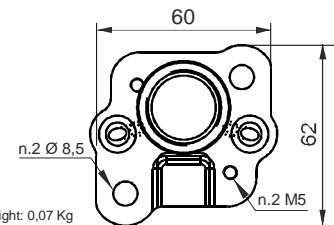

Weight: 0,07 Kg

Standard rotation direction: clockwise rotation (from shaft side).
Counterclockwise rotation pumps can be mounted on request.
Ask our sales department.

Spare part code

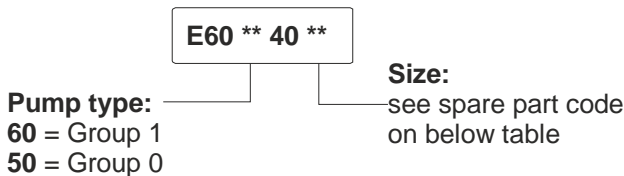

PPC assembly code field

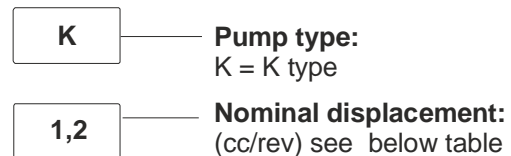

Available range

Nominal Displacement (cc/rev)	Peak pressure (bar)	Intermittent pressure (bar)	Continuous pressure (bar)	Max speed (rpm)	N (mm)	Bolts* (mm)	Spare part code	Weight
0,2	200	180	160	6000	45,5	M5x55	E60504002	0,33 Kg
0,4	200	180	160	6000	47,5	M5x55	E60504004	0,35 Kg
0,6	200	180	160	6000	51,5	M5x60	E60504006	0,40 Kg

Other pumps executions with different pressure/speed ratings are available on request.

* A proper washer is to be forecast to adapt bolt length

H TYPE HIGH PRESSURE GEAR PUMPS

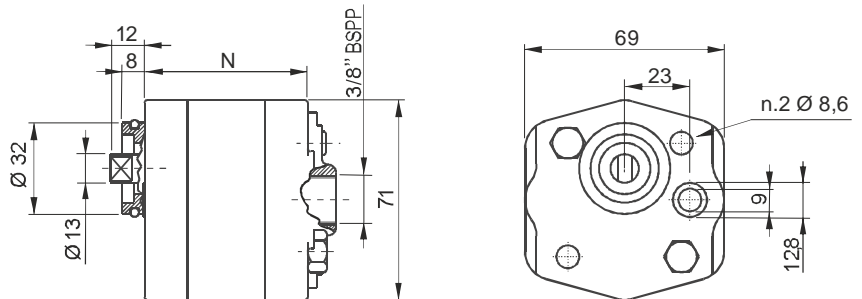

Main features

Oil temperature	-15 ÷ +80 °C
Inlet pressure	0,7 < P < 3,0 bar (absolute pressure)
Fixing bolts	2 x M8 8.8 class steel tightening torque: 25 Nm
Pressure definition	Peak pressure: cycle 2 s ON Intermittent pressure: cycle 20 s ON Continuous pressure: cycle always ON
Filtration setting	25 ÷ 50 µ

Standard rotation direction: clockwise rotation (from shaft side).
Counterclockwise rotation pumps can be mounted on request.
Ask our sales department.

Spare part code

E60 60 50 **

Size:
see spare part code
on below table

PPC assembly code field

H	Pump type: H = H type
1,2	Nominal displacement: (cc/rev) see below table

Available range

Nominal Displacement (cc/rev)	Peak pressure (bar)	Intermittent pressure (bar)	Continuous pressure (bar)	Max speed (rpm)	N (mm)	Bolts* (mm)	Spare part code	Weight
1,2	280	270	250	5000	40	M8x55	E60605002	0,5 Kg
1,7	280	270	250	4500	41	M8x55	E60605035	0,52 Kg
2,2	280	270	250	4500	44	M8x55	E60605004	0,54 Kg
2,6	280	270	250	4500	46	M8x60	E60605005	0,56 Kg
3,2	280	270	250	4000	52	M8x65	E60605006	0,58 Kg
3,8	280	270	250	3800	55	M8x70	E60605007	0,61 Kg
4,2	280	270	250	3500	82	M8x95	E60605008	1,05 Kg
4,7	260	250	240	3200	84	M8x100	E60605009	1,12 Kg
6,0	230	220	210	3000	94	M8x110	E60605010	1,22 Kg

Other pumps executions with different pressure/speed ratings are available on request.

* Proper washers are to be forecast to adapt bolt length

BIDIRECTIONAL GEAR PUMPS. GROUP 0

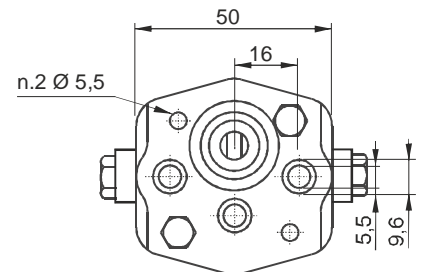
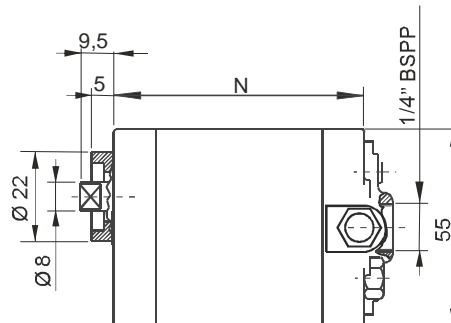

Main features

Oil temperature	-15 ÷ +80 °C
Inlet pressure	0,7 < P < 3,0 bar (absolute pressure)
Fixing bolts	2 x M8 8.8 class steel tightening torque: 25 Nm
Pressure definition	Peak pressure: cycle 2 s ON Intermittent pressure: cycle 20 s ON Continuous pressure: cycle always ON
Filtration setting	25 ÷ 50 µ

**Aluminium adapter flange for group 0
Code: E60513025**

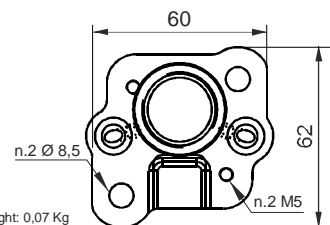

Standard rotation direction: clockwise rotation (from shaft side).
Counterclockwise rotation pumps can be mounted on request.
Ask our sales department.

Spare part code

E605045 **

Size:
see spare part code
on below table

PPC assembly code field

R

Pump type:
R = Reversible type

1,3

Nominal displacement:
(cc/rev) see below table

Available range

Nominal Displacement (cc/rev)	Peak pressure (bar)	Intermittent pressure (bar)	Continuous pressure (bar)	Max speed (rpm)	N (mm)	Bolts* (mm)	Spare part code	Weight
0,1	190	170	150	6000	45,5	M5x55	E60503501	0,44 Kg
0,2	200	180	160	6000	45,5	M5x55	E60504502	0,46 Kg
0,4	200	180	160	6000	47,5	M5x55	E60504504	0,48 Kg
0,6	200	180	160	6000	54,5	M5x60	E60504506	0,49 Kg
0,9	200	180	160	5000	62,4	M5x60	E60504509	0,50 Kg
1,3	200	180	160	3900	63,2	M5x65	E60504513	0,51 Kg
1,5	200	180	160	3900	64,5	M5x65	E60504515	0,52 Kg

* A proper washer is to be forecast to adapt bolt length
For higher displacement please ask to our technical department

DOUBLE GEAR PUMPS

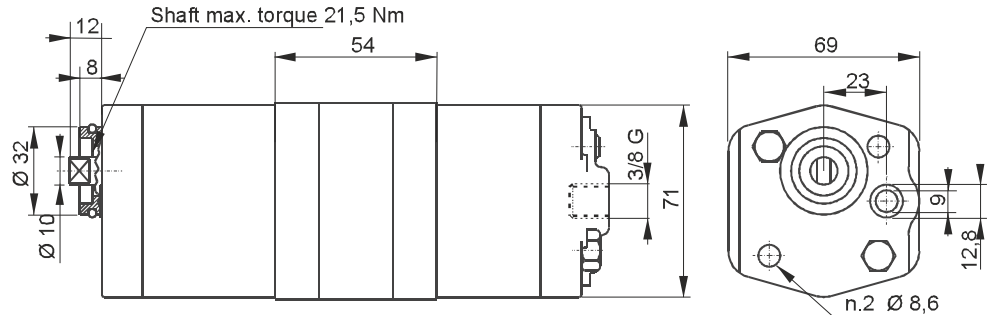

Commune 3/8" BSSP inlet port (on the rear cover) alternatively individual inlet side ports are available

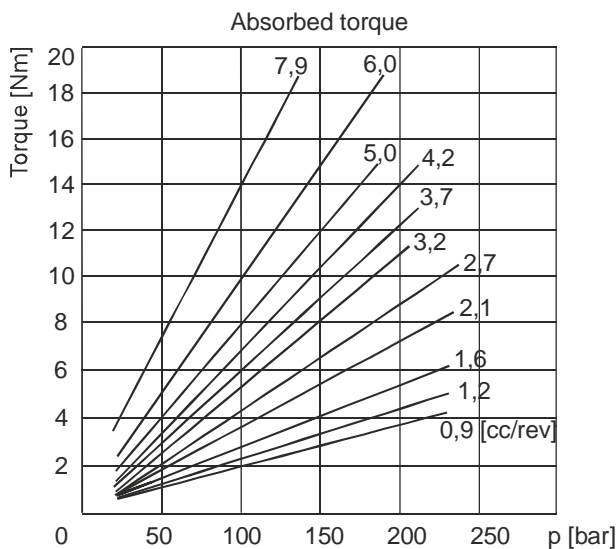

PPC assembly code field

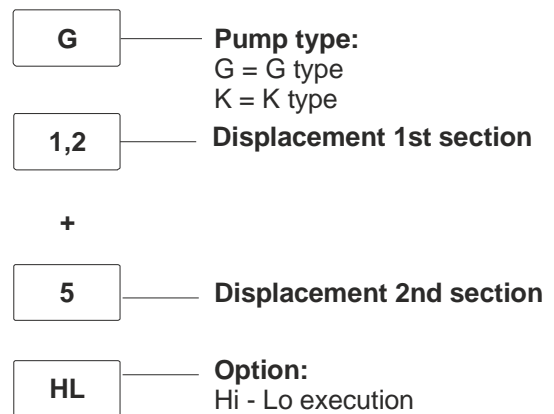

Standard combinations available

Type	Nominal Displacement (cc/rev)	Peak pressure (bar)	Intermittent pressure (bar)	Continuous pressure (bar)	Unloading pressure (bar)	Max speed (rpm)	Spare part code	Weight
K0,9+3,2HL	0,9 + 3,2	250	230	210	42±5	1750	E60600932HL	2,12 Kg
K1,2+5HL	1,2 + 5,0	250	230	210	42±5	1750	E60601250HL	2,29 Kg

PUMPS CHOICE DIMENSIONING:

- Check that the power absorption of the front element is equal or higher than the rear one
- Element performance and features are the same as the elements of corresponding single pumps
- Double pump maximum rotation speed is determined by the lowest speed among maximum rotation speeds of each single element
- Torque applied on the shaft of the first element is the addition of the torques absorbed by the two pumps (see above diagram); this value must never go over the limit value allowed for the shaft (21,5 Nm).

HI-LO

It's an efficient and energy saving solution for applications where you need a fast approach and an high pressure working phase (industrial presses, garbage compactors, balers,...). During the high speed phase both pumps are supplying flow to the system while during the high pressure phase, the high flow pump is discharged back to tank with no load. This solution can be conveniently realized with our UA or UB or U4 central manifold without any additional kit. Ask to our technical office for more details.

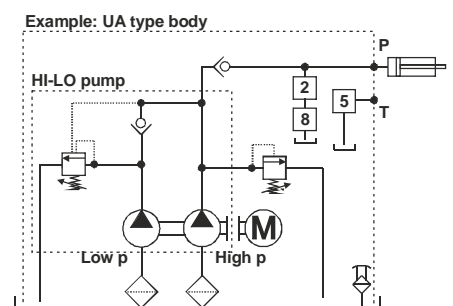

HELICAL ROTOR PUMPS FOR HIGH PRESSURE, HIGH FLOW AND LOW NOISE APPLICATIONS

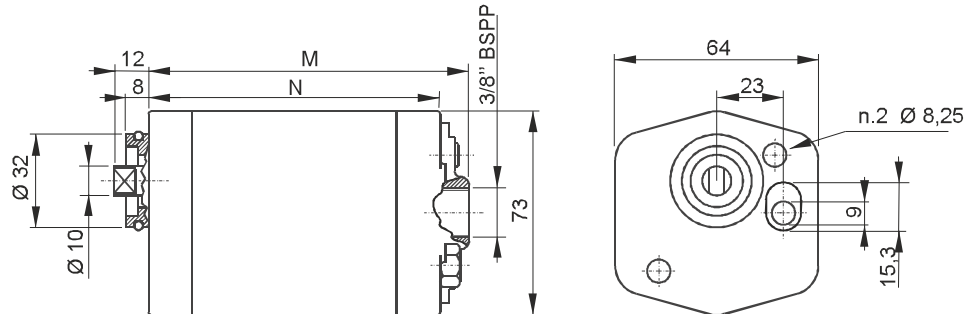

Main features

Oil temperature	-15 ÷ +80 °C
Inlet pressure	0,7 < P < 2,0 bar (absolute pressure)
Weight	2 ÷ 2,5 Kg
Filtration setting	30 ÷ 50 µ
Fixing bolts	2 x M8 8.8 class steel tightening torque: 25 Nm
Pressure definition	Peak pressure: cycle 1 sec. & 3 sec. OFF Intermittent pressure: cycle 20 sec. & 3 sec. OFF Continuous pressure: cycle always ON

Available range

PPC code	Displacement (cc/rev)	Peak pressure (bar)	Intermittent pressure (bar)	Continuous pressure (bar)	Max speed (rpm)	N (mm)	M (mm)	Noise level (dbA)	Spare part code
S4,2	4,2	250	230	200	3600	88	95	55	S60603008
S6,4	6,4	250	230	200	3600	93	100	55	S60603010
S8,3	8,3	215	195	153	3600	98	105	55	S60603012
S10	10,2	190	170	126	3600	103	110	55	S60603014
S13	12,9	160	140	99	3600	110	117	55	S60603016

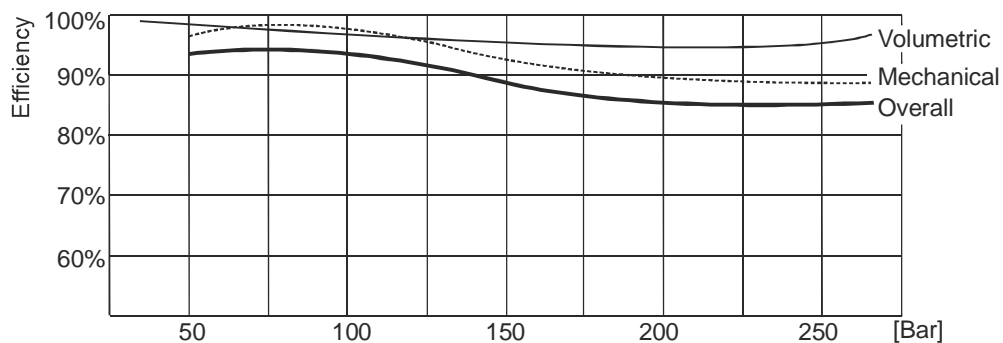

Note: Reference values measured at 1500 rpm with an oil viscosity of 46 cSt at 40 °C.

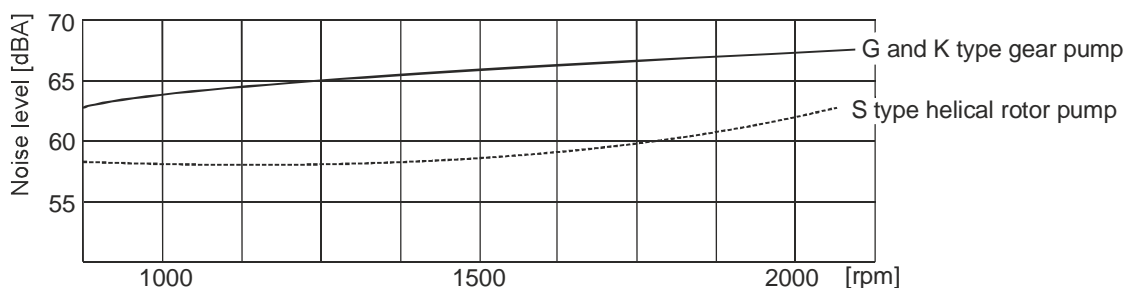

Note: Reference values measured in air at 1500 rpm with an oil viscosity of 46 cSt at 40 °C.

INTEGRAL COMPONENTS

Two way no leakage solenoid valves SAE08 (3/4-16UNF) are available in Normally Closed, Normally Open, single and double locking executions. Manual override also available.



The PMC02 cartridge hand pump SAE08 (3/4-16UNF), 2 cc/stroke is an affordable and easy way to add an emergency function to your power pack.



VSC flow control valves are pressure compensated to keep a stable lowering speed of single acting cylinders independently of the load



The main relief valve is fitted in a M20x1,5 cavity and is built with a guided poppet to improve pressure setting stability and avoid the typical noise of lower cost alternative valves



The main check valve fits in a SAE08 (3/4-16UNF) standard cavity and can be easily unmounted from the outside for easy cleaning and servicing



All cartridges are supplied in single piece, easily screwable

How does the coding of the power pack works?

The power packs are coded with a speaking code, which is basically the list of subassemblies which make up the power pack (motor, pump, valves, tank,...). Integral components are those fitting inside central manifold cavities, which are numbered from 0 to 8. Each component has an assembly code, normally a single letter which compose the speaking code, and a spare part code in case they are ordered as loose components. The numbered cavities are indicated in the hydraulic scheme too, so that it is easy to draw it starting from the speaking code itself

There are several different coils and connectors for the cartridge solenoid valves. How do I choose the proper ones?

Normally closed 2-way solenoid valves (MSV30*) use M130 series of coils either DC or directly AC. Normally open 2-way solenoid valves (MSV31E) can only use DC or RAC (rectified current) coils due to their constructive principle. Both can use M140 series of coils for enhanced performances. When choosing a RAC coil, a rectifying bridge connector must be chosen (KA132R***). MSV4V 4-way cartridge valves use the new M63*** series coils. M630 are for DC supply voltage, while M631 are rectified coils with integral rectifying bridge, to be supplied with AC current. A standard KA13200000 connector must be always used in this case.

Which are the mostly used plugs?

G or H plugs are normally fitted in cavity 2 and 4, of UA and UB central manifolds when these cavities are not used. H type has an exit 1/4" BSP port to allow mounting of a pressure gauge or switch. L type plug goes in cavity 3 of U4 and UB manifolds, when this cavity is not used.

VMDC35 - DIRECT ACTING MAIN RELIEF VALVE

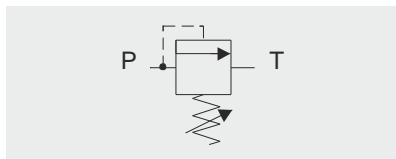
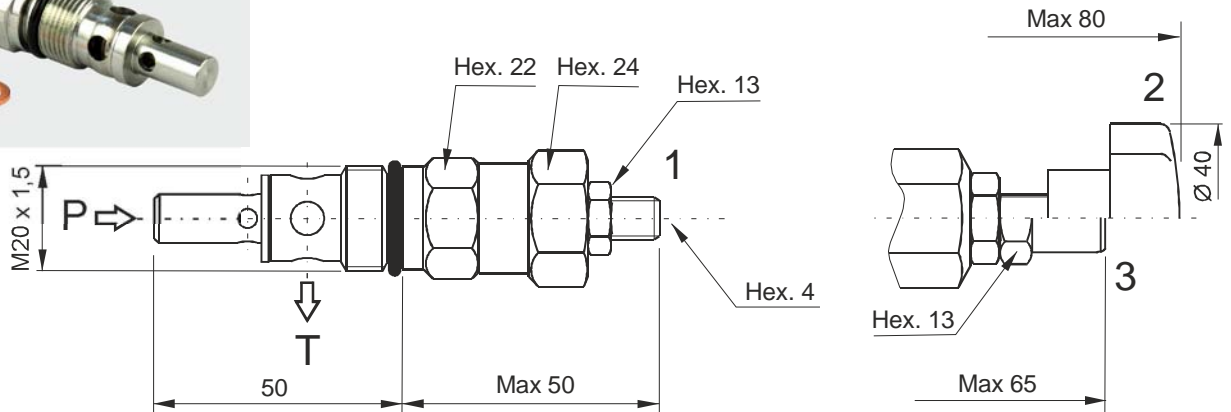

Main features

Max pressure	450 bar
Max flow	35 l/min
Weight	0,16 kg

Recommended tightening torque: 50 Nm
 Recommended filtration settings: 25 ÷ 50 µ
 Oil temperature: -30 ÷ + 80 °C

PPC assembly code field

D/***

where *** stands for max setting pressure [bar]. Ex. D/280

where stands for option other than the standard one.

Mounting cavities

0	1		
2	3	4	
5	6	7	8

Note: cavities 3, 4 and 6 are present on central manifold type UB only.

Spare part code

- VMDC** — Direct acting main relief valve
- 35** — Nominal size: 35 = 35 l/min
- B** — Working range: L = 10 ÷ 60 bar, A = 20 ÷ 180 bar, B = 35 ÷ 280 bar, C = 60 ÷ 350 bar
- 1** — Option: 1 = screw (std), 2 = handwheel, 3 = with cap, 4 = plastic seal

Minimum setting pressure

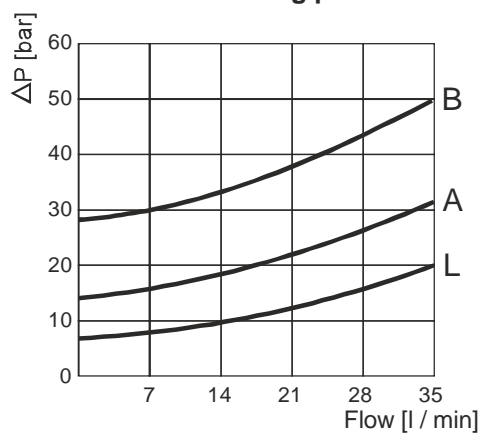

Pressure vs flow

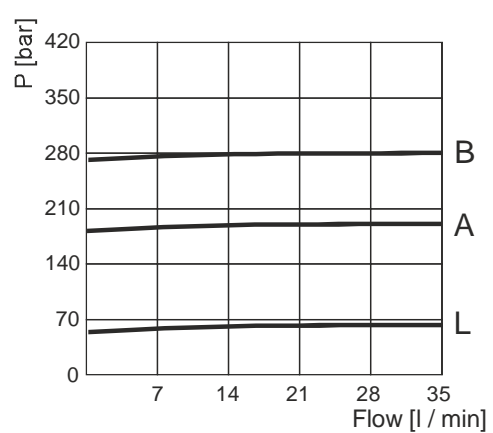

Note: Values measured on valve alone (no cavity) with an oil viscosity of 46 cSt at 50 °C. Pressure drop may change depending on fluid viscosity and temperature

VMDC20 - DIRECT ACTING RELIEF VALVE

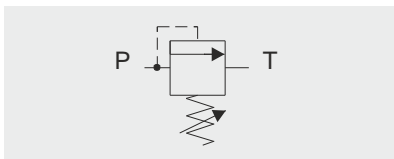
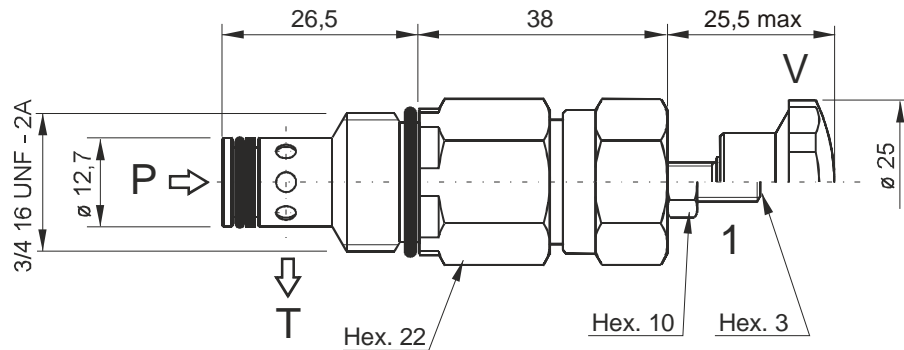

Main features

Max pressure	350 bar
Max flow	20 l/min
Weight	0,14 kg

Recommended tightening torque: 40 Nm
 Recommended filtration settings: 25 ÷ 50 µ
 Oil temperature: -30 ÷ + 80 °C

PPC assembly code field

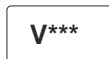

where *** stands for max setting pressure [bar]. Ex. V250

where stands for adjustment other than the standard one

Mounting cavities

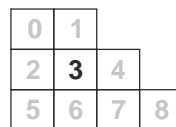

Note: cavities 3, 4 and 6 are present on central manifold type UB only.

Spare part code

- VMDC** — Direct acting relief valve
- 20** — Nominal size: 20 = 20 l/min
- B** — Working range:
 - A = 10 ÷ 40 bar
 - B = 20 ÷ 110 bar
 - C = 30 ÷ 250 bar
 - D = 70 ÷ 350 bar
- 1** — Adjustment:
 - 1 = screw (std)
 - V = handwheel

Minimum setting pressure

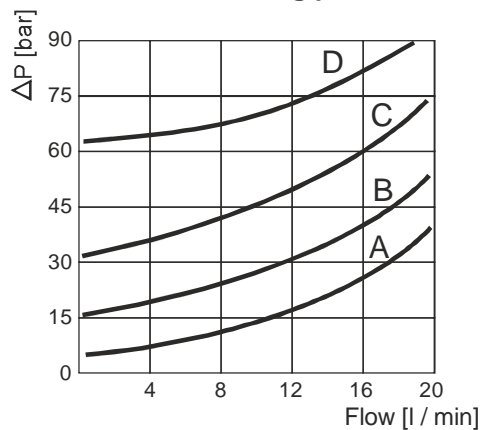

Pressure vs flow

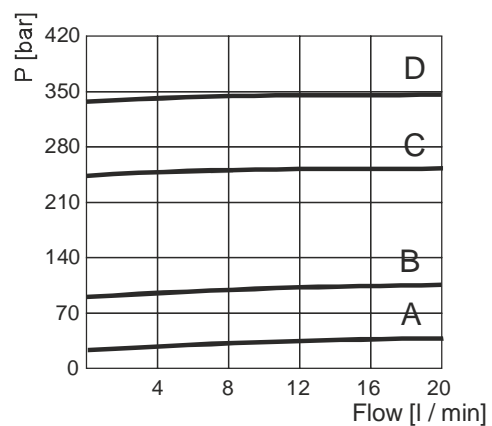

Note: Values measured on valve alone (no cavity) with an oil viscosity of 46 cSt at 50 °C. Pressure drop may change depending on fluid viscosity and temperature

VCF6 - PRESSURE COMPENSATED FLOW CONTROL VALVE

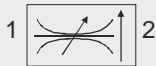
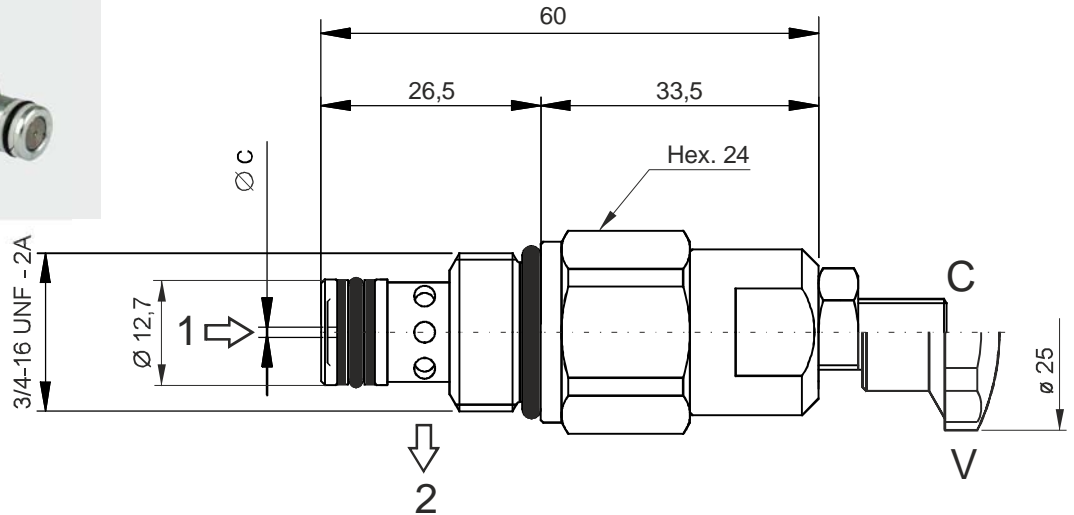

Main features

Max pressure	350 bar
Max flow	18 l/min
Weight	0,11 kg

Recommended tightening torque: 25 Nm
 Recommended filtration settings: 25 ÷ 50 µ
 Oil temperature: -30 ÷ + 80 °C

PPC assembly code field

R *

where * stands for nominal dimension

Mounting cavities

0	1		
2	3	4	
5	6	7	8

Note: cavities 3, 4 and 6 are present on central manifold type UB only.

Spare part code

- VCF6** — Flow control valve pressure compensated
- *** — Nominal dimension: See table below
- C** — Adjustment:
C = screw (std)
V = handwheel

Nominal dimension	C	Controlled flow at 100 bar ± 10% l/min
2	0,6	1,0 - 2,2
3	1,0	1,6 - 4,0
4	1,2	2,5 - 5,0
5	1,8	3,0 - 7,0
6	2,8	4,9 - 10,8
7	4,8	8,0 - 18,5

Pressure drop diagram

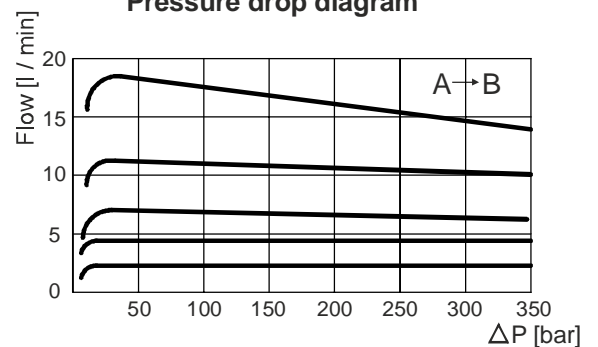

Note: Values measured on valve alone (no cavity) with an oil viscosity of 46 cSt at 50 °C. Pressure drop may change depending on fluid viscosity and temperature

CSB - BIDIRECTIONAL FLOW CONTROL VALVE

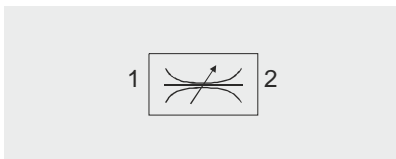
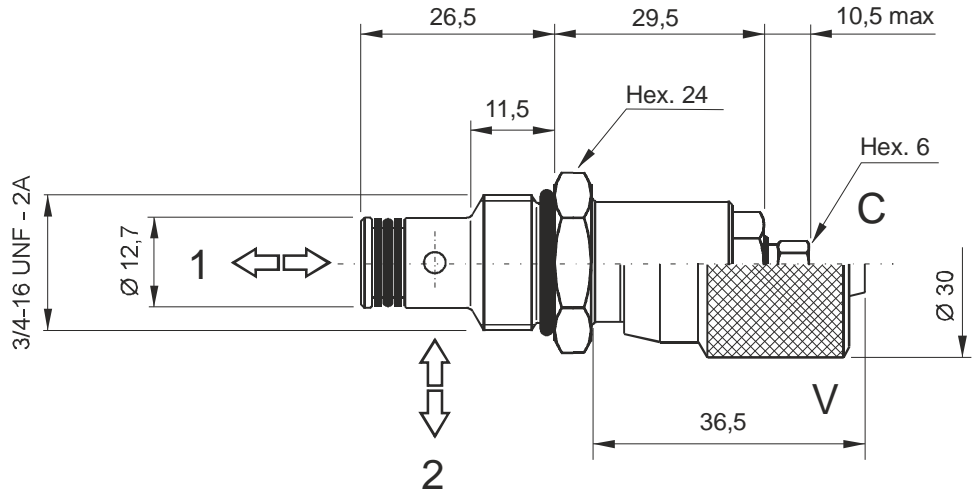

Main features

Max pressure	300 bar
Max flow	15 l/min
Weight	0,08 kg

Recommended tightening torque: 25 Nm
 Recommended filtration settings: 25 ÷ 50 µ
 Oil temperature: -30 ÷ + 80 °C

PPC assembly code field

S

Mounting cavities

0	1		
2	3	4	
5	6	7	8

Note: cavities 3, 4 and 6 are present on central manifold type UB only.

Spare part code

- CSB** — Flow control valve
- 04** — Nominal size:
04 = 3/4-16 UNF
- C** — Adjustment:
C = screw (std)
V = handwheel

Pressure drop diagram

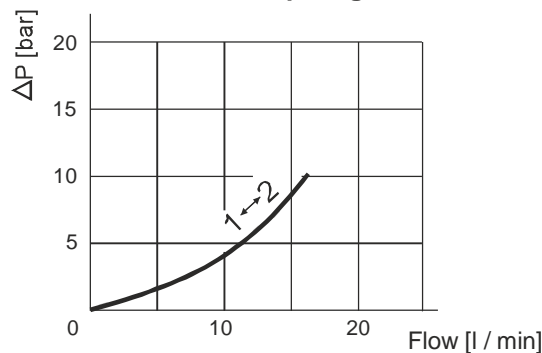

Note: Values measured on valve alone (no cavity) with an oil viscosity of 46 cSt at 50 °C. Pressure drop may change depending on fluid viscosity and temperature

VSC01 - PRESSURE COMPENSATED FIXED FLOW CONTROL VALVE



Controlled flow

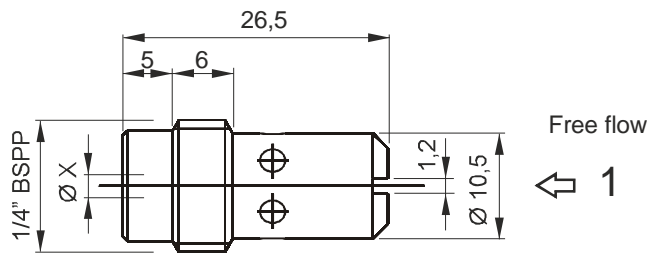

Typical application

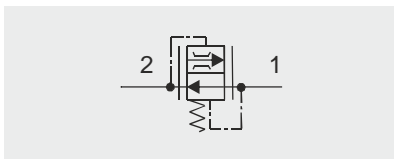
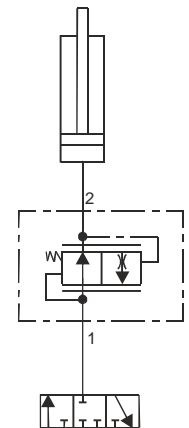

Main features

Max pressure	250 bar
Max flow	15 l/min
Weight	0,012 kg

Recommended tightening torque: 6 Nm
 Recommended filtration settings: 25 ÷ 50 µ
 Oil temperature: -30 ÷ + 80 °C

PPC assembly code field

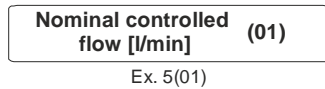

Mounting cavities

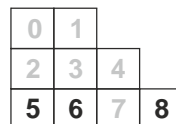

Note: cavities 3, 4 and 6 are present on central manifold type UB only.

Spare part code

- VSC — Flow control valve pressure compensated
- 01 — Nominal size: 01= 1/4" BSPP
- E — Controlled flow: A, B, C, D, E, F, H, L, M, N

Controlled flow through X port 2 → 1

Spare part code	Ø X [mm]	Nominal controlled flow [l/min]
VSC01A	1	1
VSC01B	1,2	2
VSC01C	1,5	3
VSC01D	1,7	4
VSC01E	1,9	5
VSC01F	2,1	6
VSC01H	2,5	8
VSC01L	2,8	10
VSC01M	3	12
VSC01N	5	15

Note: nominal controlled flow, measured at 100 bar with an oil viscosity of 46 cSt at 40 °C, are to be taken as general reference values and must be tested on the field.

Free flow pressure drop 1 → 2

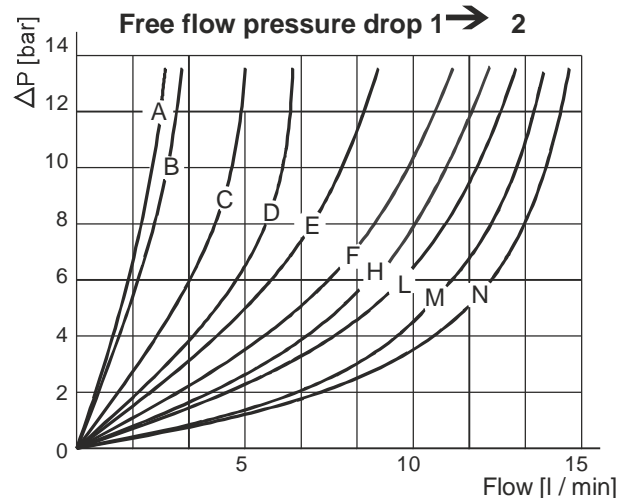

Note: Values measured on valve alone (no cavity) with an oil viscosity of 46 cSt at 40 °C. Pressure drop may change depending on fluid viscosity and temperature

VSC04 - PRESSURE COMPENSATED FIXED FLOW CONTROL VALVE

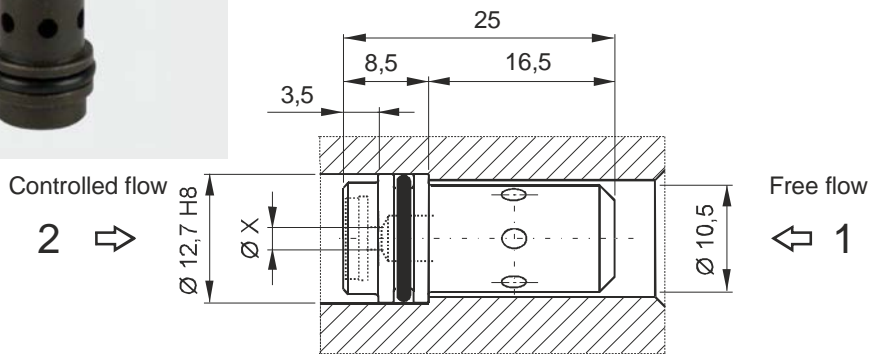

Typical application

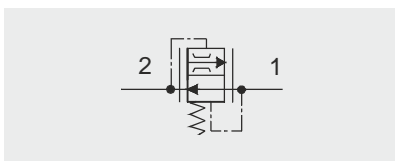
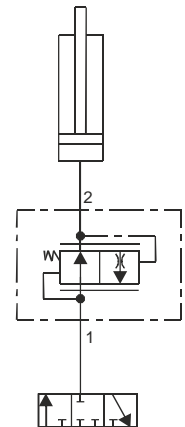

Main features

Max pressure	250 bar
Max flow	15 l/min
Weight	0,012 kg

PPC assembly code field

Nominal controlled flow [l/min] (04)
Ex. 5(04)

Mounting cavities

0	1
2	3 4
5	6 7 8

Note: cavities 3, 4 and 6 are present on central manifold type UB only.

Spare part code

- VSC — Flow control valve pressure compensated
- 04 — Nominal size: 04
- 02 — Controlled flow: 00, 01, 02, 03, 04, 05, 06, 08, 10, 12, 15

Recommended filtration settings: 25 ÷ 50 µ
Oil temperature: -30 ÷ + 80 °C

Controlled flow through X port 2 → 1

Spare part code	Ø X [mm]	Nominal controlled flow [l/min]
VSC0400	Closed	0
VSC0401	0,8	1
VSC0402	1	2
VSC0403	1,25	3
VSC0404	1,5	4
VSC0405	1,75	5
VSC0406	2	6
VSC0408	2,75	8
VSC0410	3,5	10
VSC0412	4	12
VSC0415	5	15

Note: nominal controlled flow, measured at 100 bar with an oil viscosity of 46 cSt at 50 °C, are to be taken as general reference values and must be tested on the field

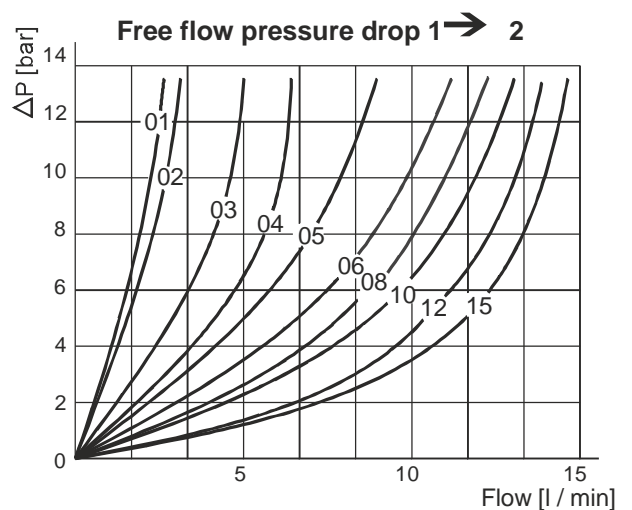

Note: Values measured on valve alone (no cavity) with an oil viscosity of 46 cSt at 50 °C. Pressure drop may change depending on fluid viscosity and temperature

VSC6 - PRESSURE COMPENSATED FIXED FLOW CONTROL VALVE

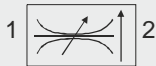
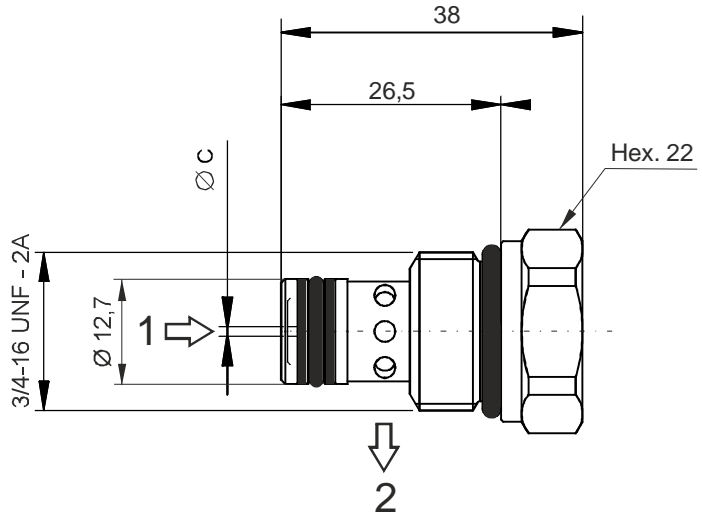

Main features

Max pressure	350 bar
Max flow	18 l/min
Weight	0,06 kg

Recommended tightening torque: 25 Nm
 Recommended filtration settings: 25 ÷ 50 µ
 Oil temperature: -30 ÷ + 80 °C

PPC assembly code field

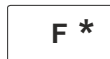

where * stands for nominal dimension

Mounting cavities

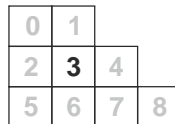

Note: cavities 3, 4 and 6 are present on central manifold type UB only.

Spare part code



Flow control valve pressure compensated



Nominal dimension: See table below

Nominal dimension	C	Controlled flow at 100 bar ± 10% l/min
02	0,8	1
03	1,0	2
04	1,25	3
05	1,5	4
06	1,75	6
07	2	8
09	2,5	11
11	3	14
13	3,5	16
15	4	20

Pressure drop diagram

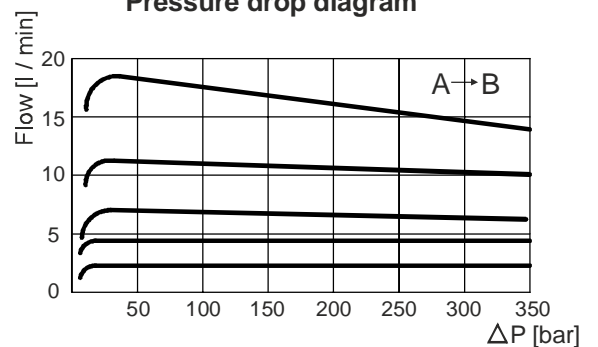

Note: Values measured on valve alone (no cavity) with an oil viscosity of 46 cSt at 50 °C. Pressure drop may change depending on fluid viscosity and temperature

VUC20 - BASIC CHECK VALVE



Option P
(E70060001)

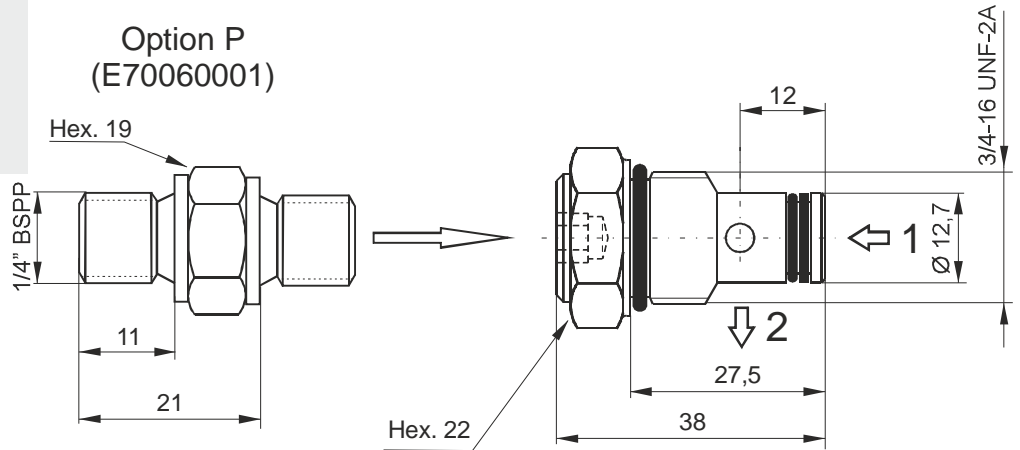

This part is typically used to connect a pressure gauge for statical pressure measurement. It is not suitable for instantaneous pressure measurement.

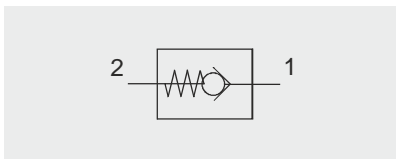

Main features

Max pressure	350 bar
Max flow	25 l/min
Weight	0,052 kg
Cracking pressure	1 bar

Recommended tightening torque: 40 Nm
Recommended filtration settings: 25 ÷ 50 µ
Oil temperature: -30 ÷ + 80 °C

PPC assembly code field

J *

where * stands for optional pressure port

Mounting cavities

0	1		
2	3	4	
5	6	7	8

Note: cavities 3, 4 and 6 are present on central manifold type UB only.

Spare part code

- VUC — Check valve
- 20 — Nominal size: 20
- — Options:
- = no options
P = pressure port 1/4" BSPP

Pressure drop diagram

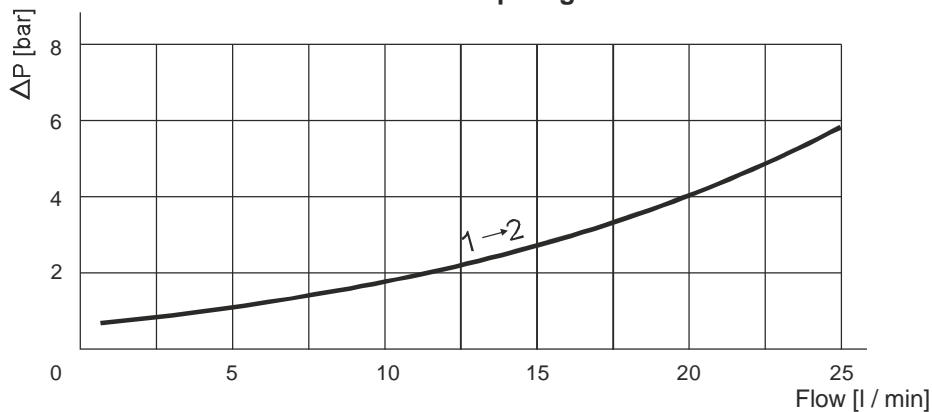

Note: Values measured on valve alone (no cavity) with an oil viscosity of 46 cSt at 50 °C. Pressure drop may change depending on fluid viscosity and temperature

CPE - MANUAL EMERGENCY VALVE

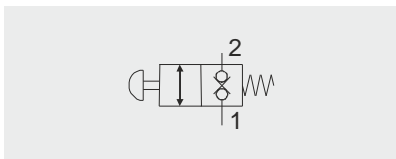
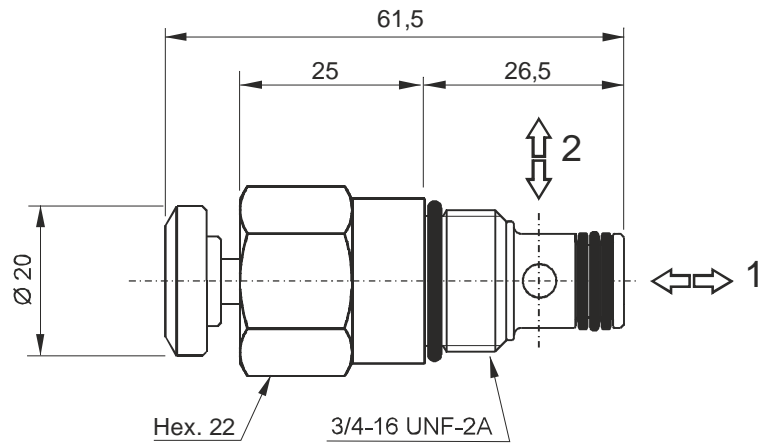

Main features

Max pressure	300 bar
Max flow	25 l/min
Weight	0,12 kg

Recommended tightening torque: 25 Nm
 Recommended filtration settings: 25 ÷ 50 µ
 Oil temperature: -30 ÷ + 80 °C

PPC assembly code field

Z

Mounting cavities

0	1		
2	3	4	
5	6	7	8

Note: cavities 3, 4 and 6 are present on central manifold type UB only.

Spare part code

- CPE** — Two-way manual emergency valve
- 04** — Nominal size:
04 = 3/4-16 UNF
- P** — Operating device:
P = press button

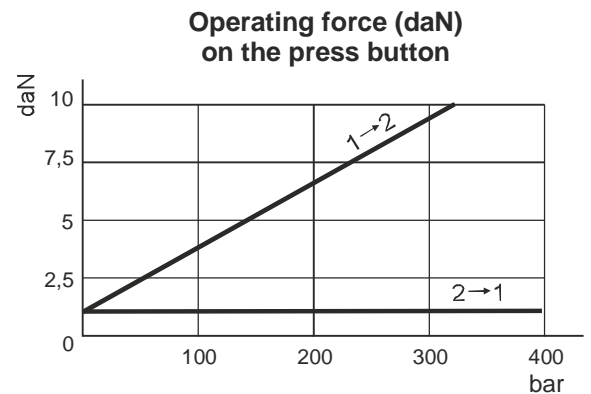
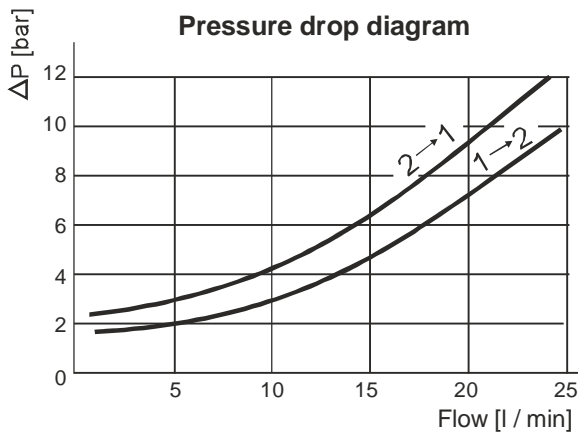

Note: Values measured on valve alone (no cavity) with an oil viscosity of 46 cSt at 50 °C. Pressure drop may change depending on fluid viscosity and temperature

CM - MANUAL LEVER VALVE

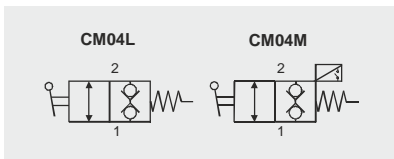
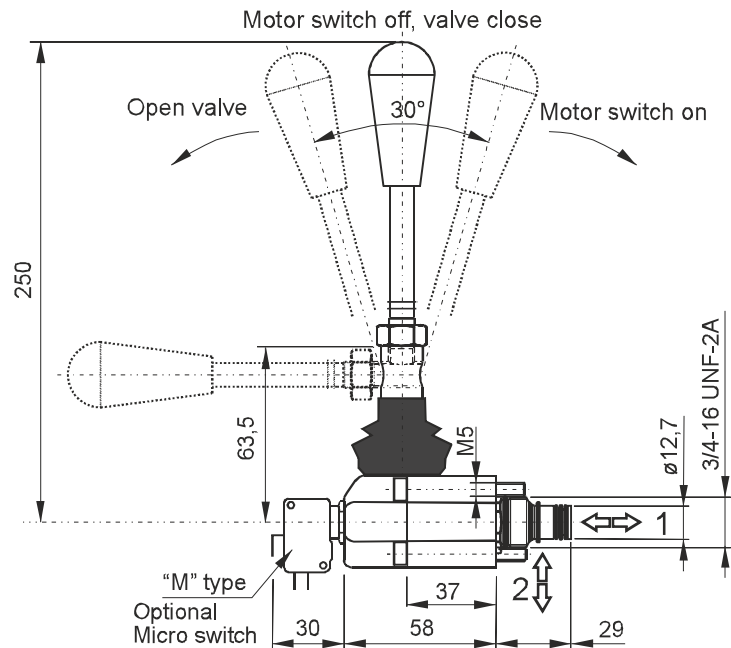

Main features

Max pressure	300 bar
Max flow	25 l/min
Weight	0,34 kg
Micro switch max current	10 A - 400 V
	16 A - 250 V

Fixing bolts: 4x M5x45 (tightening torque: 5 Nm)
 Recommended cartridge tightening torque: 20 Nm
 Recommended filtration settings: 25 ÷ 50 µ
 Oil temperature: -30 ÷ + 80 °C

PPC assembly code field

E (CM04L)
 EM (CM04M)

Mounting cavities

0	1		
2	3	4	
5	6	7	8

Note: cavities 3, 4 and 6 are present on central manifold type UB only.

Spare part code

- CM** — Two-way manual lever valve
- 04** — Nominal size: 04 = 3/4-16 UNF
- L** — Type: L = lever (std), M = lever + micro switch

Pressure drop diagram

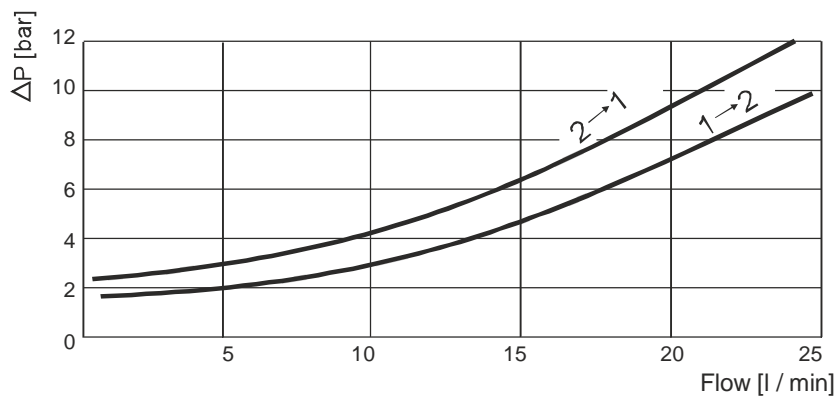

Note: Values measured on valve alone (no cavity) with an oil viscosity of 46 cSt at 50 °C. Pressure drop may change depending on fluid viscosity and temperature

PMC - CARTRIDGE HAND PUMP

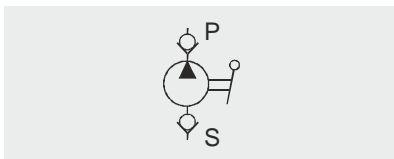
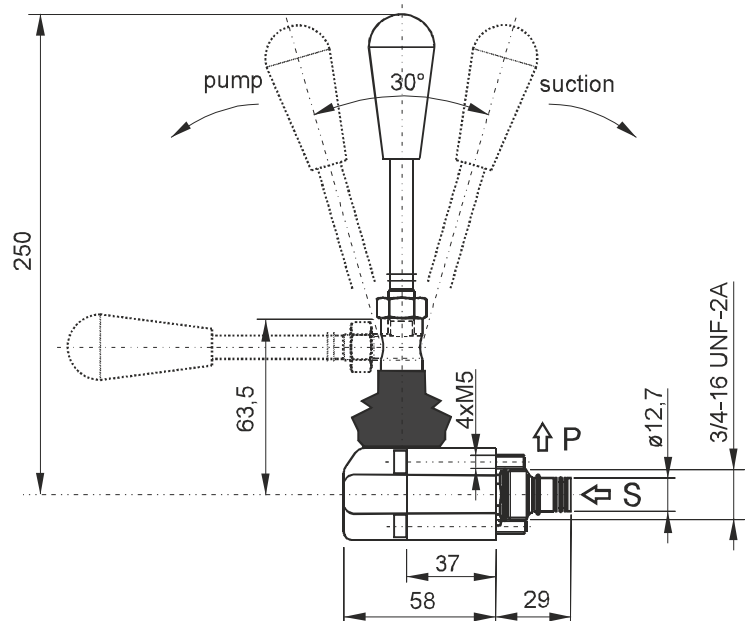

Main features

Max pressure	200 bar
Max flow	-
Weight	0,34 kg

Fixing bolts: 4x M5x45 (tightening torque: 5 Nm)
 Recommended cartridge tightening torque: 15 Nm
 Recommended filtration settings: 25 ÷ 50 µ
 Oil temperature: -30 ÷ + 80 °C

PPC assembly code field

U

Mounting cavities

0	1		
2	3	4	
5	6	7	8

Note: cavities 3, 4 and 6 are present on central manifold type UB only.

Spare part code

- PMC — Hand pump
- 02 — Nominal size:
02 = 2 cc/stroke
- L — Type:
L = lever (std)

Effort (daN)
operating on the lever end

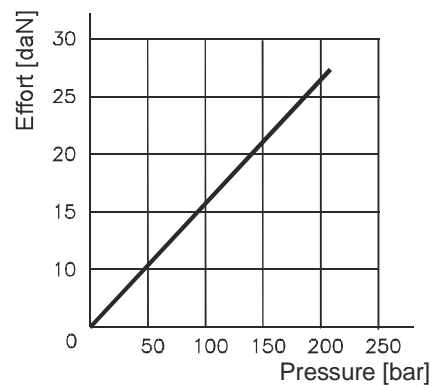

Note: Values measured on valve alone (no cavity) with an oil viscosity of 46 cSt at 50 °C. Pressure drop may change depending on fluid viscosity and temperature

MSV - PILOT OPERATED TWO-WAY SINGLE LOCKING SOLENOID VALVE



Options:

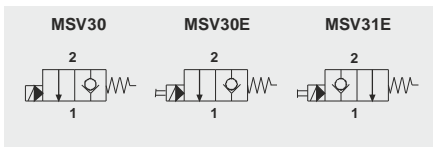
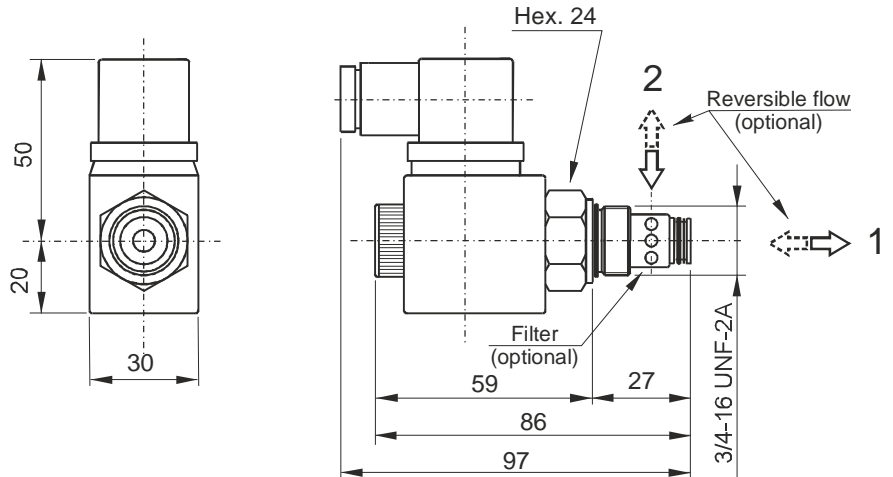
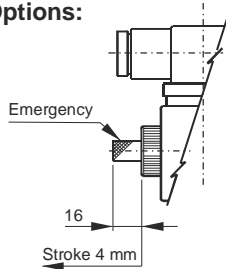

Main features

Max pressure	210 bar (up to 300bar*)
Max flow	25 l/min
Weight	0,27 Kg (with coil)
Coil thermal insulation	Class F (Class H*)
Electric connection	DIN 43650-A / ISO 4400
Coil protection degree	IP 65 / DIN 40050
Duty cycle	ED 75% (ED 100%*)
Voltage required	+/- 10% nominal voltage
Normatives	EN50081-1/EN50082-2 (89/336 CEE electromagnetic comp.) 73/23/CEE / 96/68/CEE (low voltage)

*: with M140 series coils only. See table U040.20.12 coils section. The max flow/max pressure cannot be achieved at the same time.

PPC assembly code field

A (MSV30) **Voltage**
B (MSV30E) **Voltage**
C (MSV31E) **Voltage**

Ex: A12DC

Mounting cavities

0	1	
2	3	4
5	6	7 8

Note: cavities 3, 4 and 6 are present on central manifold type UB only.

Spare part code

- MSV** — Two-way pilot operated solenoid valve
- — Options:
R = with reversible flow
- 30** — Operation:
30 = normally closed
31 = normally open
- 0** — Emergency override:
0 = no emergency (std)
E = emergency
- 0000** — Supply voltage:
0000 = no coil (std)
see below table

Coils section

Supply voltage (V)	Coil type	Spare coil code	Spare connector code	Holding power consumption
12DC	12DC	M13040001	KA132000B1	18W
24DC	24DC	M13040002	KA132000B1	18W
24AC/50 Hz 60 Hz	24DC	M13040002	KA132R11B1	18W
115AC/50 Hz 60 Hz	110RC	M13040004	KA132R12B1	18W
230AC/50 Hz 60 Hz	220RC	M13040005	KA132R13B1	18W
115AC/50Hz*	115/50AC	M13040006	KA132000B1	28VA
230AC/50Hz*	230/50AC	M13040007	KA132000B1	28VA

*Only for MSV30*NC valves.
Other voltages and electric connectors types (Amp Juor, flying leads,...) are available on request.
Inrush power consumption can be up to 3,5 times higher than the holding one.

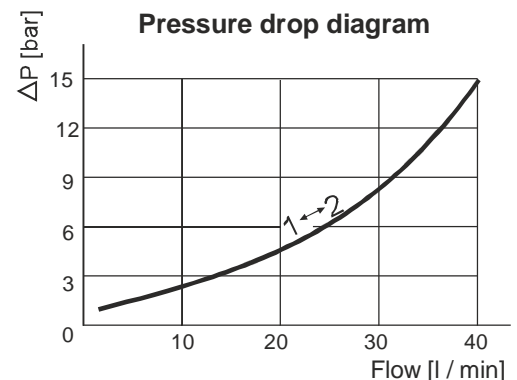

Recommended tightening torque: 45 Nm
Recommended filtration settings: 25 ÷ 50 μ
Oil temperature: -30 ÷ + 80 °C

Note: Values measured on valve alone (no cavity) with an oil viscosity of 46 cSt at 50 °C. Pressure drop may change depending on fluid viscosity and temperature

MDV - DIRECT OPERATED TWO-WAY DOUBLE BLOCKING SOLENOID VALVE

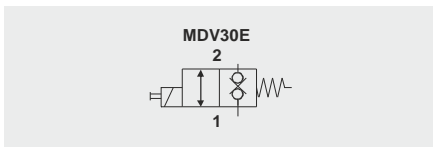
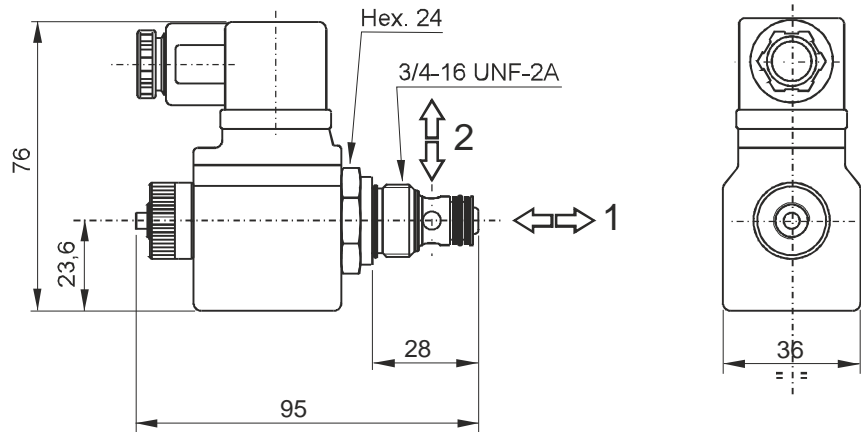

Main features

Max pressure	210 bar
Max flow	15 l/min
Weight	0,34 Kg (with coil)
Coil thermal insulation	Class H
Electric connection	DIN 43650-A / ISO 4400
Coil protection degree	IP 65 / DIN 40050
Duty cycle	ED 75% (ED 100%*)
Voltage required	+/- 10% nominal voltage
Normatives	EN50081-1/EN50082-2 (89/336 CEE electromagnetic comp.) 73/23/CEE / 96/68/CEE (low voltage)

*: with M140 series coils only. See table U040.20.12 coils section. The max flow/max pressure cannot be achieved at the same time.

PPC assembly code field

D Voltage
Ex: D24DC

Mounting cavities

0	1		
2	3	4	
5	6	7	8

Note: cavities 3, 4 and 6 are present on central manifold type UB only.

Spare part code

- MDV** — Two-way double blocking solenoid valve
- 30** — Operation: 30 = normally closed
- E** — Options: E = emergency (std)
- 0000** — Supply voltage: 0000 = no coil (std) see below table

Coils section

Supply voltage (V)	Coil type	Spare coil code	Spare connector code	Holding power consumption
12DC	12DC	M14040001	KA132000B1	22W
24DC	24DC	M14040002	KA132000B1	22W
24AC/50 Hz 60 Hz	24DC	M14040002	KA132R11B1	22W
115AC/50 Hz 60 Hz	110RC	M14040004	KA132R12B1	22W
230AC/50 Hz 60 Hz	220RC	M14040005	KA132R13B1	22W

Pressure drop diagram

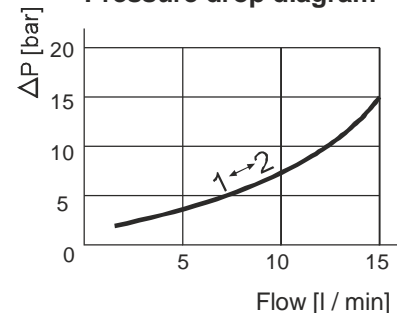

Recommended tightening torque: 45 Nm
Recommended filtration settings: 25 ÷ 50 µ
Oil temperature: -30 ÷ + 80 °C

Note: Values measured on valve alone (no cavity) with an oil viscosity of 46 cSt at 50 °C. Pressure drop may change depending on fluid viscosity and temperature

Other voltages and electric connectors types (Amp Junior, flying leads,...) available on request.
Inrush power consumption can be up to 3,5 times higher than the holding one.

MSV4V - DIRECT OPERATED 4/3 OR 4/2 DIRECTIONAL SPOOL SOLENOID VALVE

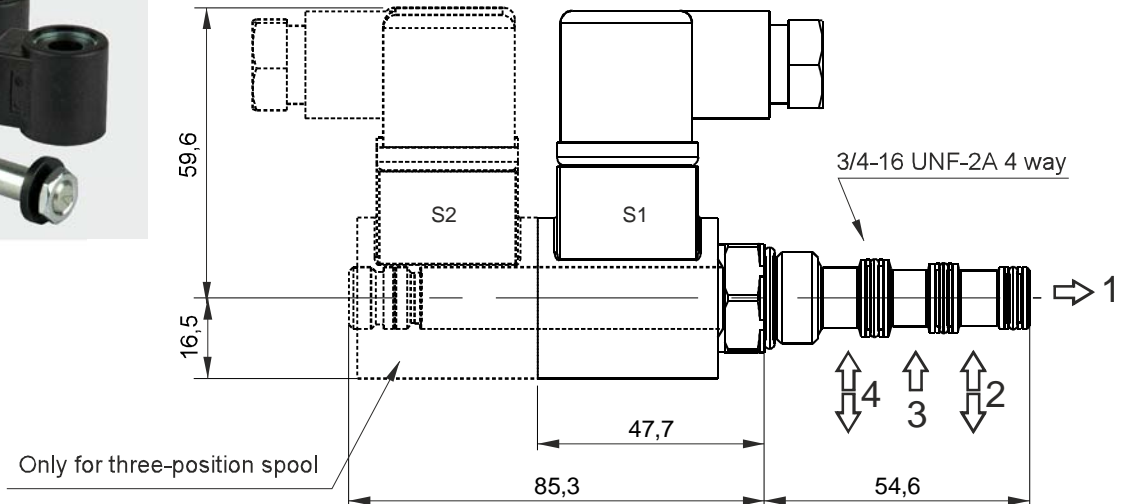

Main features

Max pressure	210 bar
Max flow	12 l/min
Weight	0,37 Kg (1 solenoid) 0,64 Kg (2 solenoid)
Coil thermal insulation	Class H)
Electric connection	DIN 43650-A / ISO 4400
Coil protection degree	IP 65 / DIN 40050
Duty cycle	ED 100%
Voltage required	+/- 10% nominal voltage
Recommended tightening torque	30 Nm
Oil temperature	-25 ÷ +70°C

PPC assembly code field

4VA2 Voltage

Ex: 4VA2 24DC

Mounting cavities

0	1	
2	3	4
5	6	7 8

Note: MSV4V can be mounted on central manifold type U4 only.

Note: cavities 3, 4 and 6 are present on central manifold type UB only.

Spare part code

- MSV4V** — 4/3 or 4/2 directional spool solenoid valve
- A2** — Spool and scheme: see side table
- 00** — Options: 00 = std
- 24DC** — Supply voltage: see below table

Coils section

Supply voltage (V)	Coil voltage	Spare coil code	Spare connector code	Holding power consumption
12DC	12DC	M6306012	KA132000B1	22W
24DC	24DC	M6306024	KA132000B1	22W
24AC/ 50 Hz 60 Hz	24AC	M6316024	KA132000B1	22W
115AC/ 50 Hz 60 Hz	115AC	M6316115	KA132000B1	22W
230AC/ 50 Hz 60 Hz	230AC	M6316230	KA132000B1	22W

Other voltages and electric connectors types (Amp Junior, flying leads,...) available on request.
Inrush power consumption can be up to 3,5 times higher than the holding one.

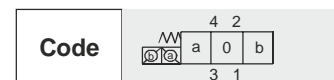

Double solenoid

A2*	
B2	
C2	
E2	

Single solenoid

A11C	
-------------	--

* = spools with price additional
Other spools are available on request

VMPC2 - PROPORTIONAL RELIEF VALVE

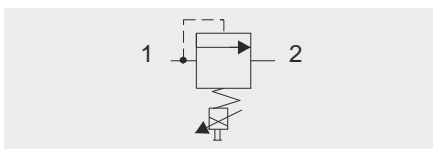
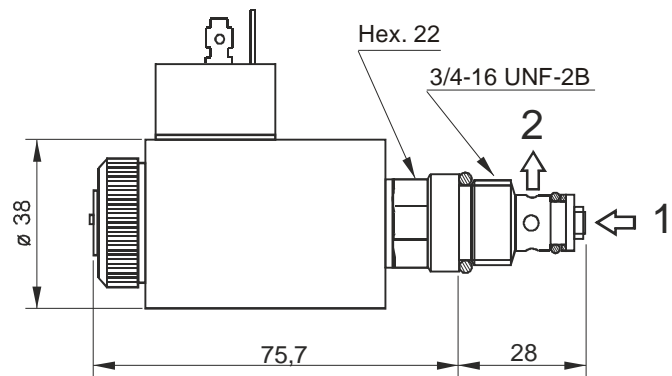

Main features

Max pressure	350 bar
Max flow	2 l/min
Weight	0,46 Kg (with coil)
Coil thermal insulation	Class H
Electric connection	DIN 43650-A / ISO 4400
Coil protection degree	IP 65 / DIN 40050
PWM	120 Hz
Hysteresis	5%
Duty cycle	ED 100%
Voltage required	+/- 10% nominal voltage
Normatives	EN50081-1/EN50082-2 (89/338 CEE electromagnetic comp.) 73/23/CEE / 99/68/CEE (low voltage)

Recommended tightening torque: 30 Nm
 Recommended filtration settings: 10 ÷ 25 µ
 Oil temperature: -40 ÷ + 80 °C

Note: Supplying current to the coil from 0 to I max (see below diagram), a proportional pressure variation is obtained on port P.

For the controller see page U040.20.16

Coils section

Supply voltage	Spare coil code	Spare connector code
12DC	M6306012	KA132000B1
24DC	M6306024	KA132000B1

Note: Values measured on valve alone (no cavity) with an oil viscosity of 46 cSt at 50 °C. Pressure drop may change depending on fluid viscosity and temperature

PPC assembly code field

P* Voltage**

where *** stands for max setting pressure [bar]. Ex. P25012DC

Mounting cavities

0	1		
2	3	4	
5	6	7	8

Note: cavities 3, 4 and 6 are present on central manifold type UB only.

Spare part code

- VMPC** — Direct acting proportional relief valve
- 2** — Nominal size
- B** — Working range:
A = 2 ÷ 60 bar
B = 3 ÷ 120 bar
C = 4 ÷ 210 bar
- — Option
- 0000** — Supply voltage:
- 0000 = no coil
- 12DC
- 24DC

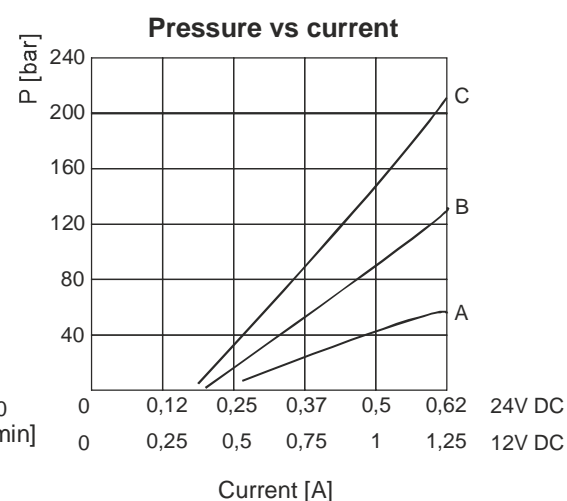
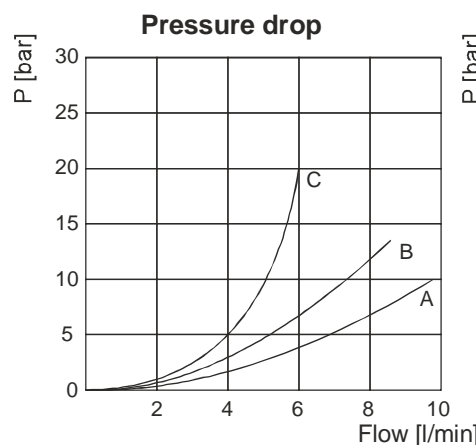

CSPC15 - PROPORTIONAL FLOW CONTROL VALVE

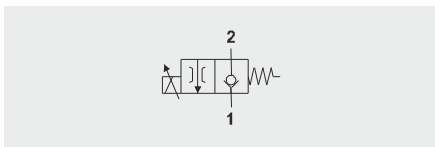
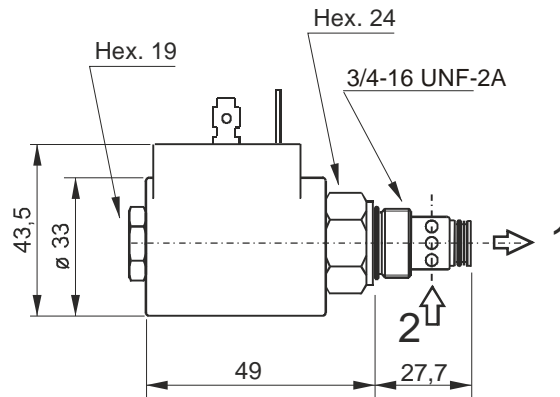

Main features

Max pressure	315 bar
Max flow	15 l/min
Weight	0,25 Kg (with coil)
Coil thermal insulation	Class H
Electric connection	DIN 43650-A / ISO 4400
Coil protection degree	IP 65 / DIN 40050
PWM	120 Hz
Hysteresis	5%
Duty cycle	ED 100%
Voltage required	+/- 10% nominal voltage
Normatives	EN50081-1/EN50082-2 (89/338 CEE electromagnetic comp.) 73/23/CEE / 96/68/CEE (low voltage)

PPC assembly code field

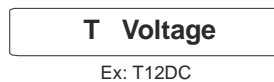

Mounting cavities

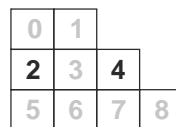

Note: cavities 3, 4 and 6 are present on central manifold type UB only.

Spare part code

- CSPC** — Proportional flow control valve
- 15** — Nominal size: 15 = 15 l/min
- 0** — Option: 0 = no options
- 0000** — Supply voltage: - 0000 = no coil - 12DC - 24DC

Recommended tightening torque: 30 Nm
Recommended filtration settings: 10 ÷ 25 µ
Oil temperature: -10 ÷ + 80 °C

Note: Supplying current to the coil from 0 to I max (see below diagram), a proportional pressure variation is obtained on port P.

For the controller see page U040.20.16

Coils section

Supply voltage	Spare coil code	Spare connector code
12DC	M6306012	KA132000B1
24DC	M6306024	KA132000B1

Pressure vs flow

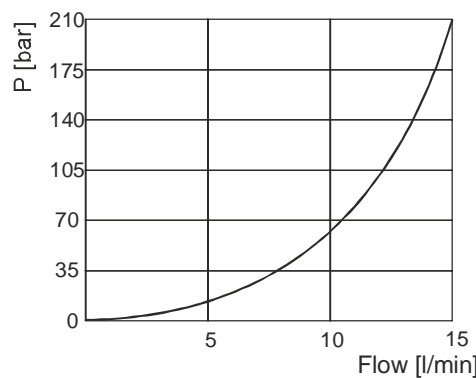

Flow vs current

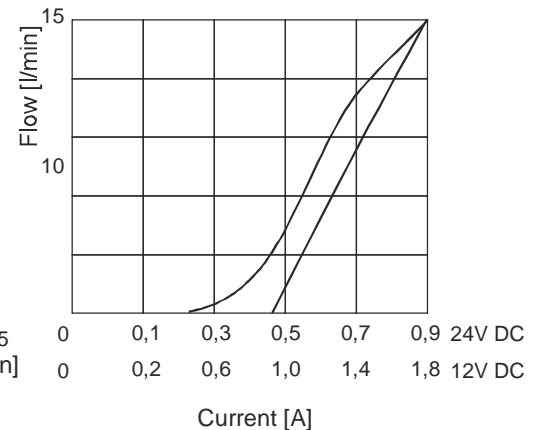

Note: Values measured on valve alone (no cavity) with an oil viscosity of 46 cSt at 50 °C. Pressure drop may change depending on fluid viscosity and temperature

VPC - ELECTRONIC AMPLIFIER FOR PROPORTIONAL SOLENOID VALVES

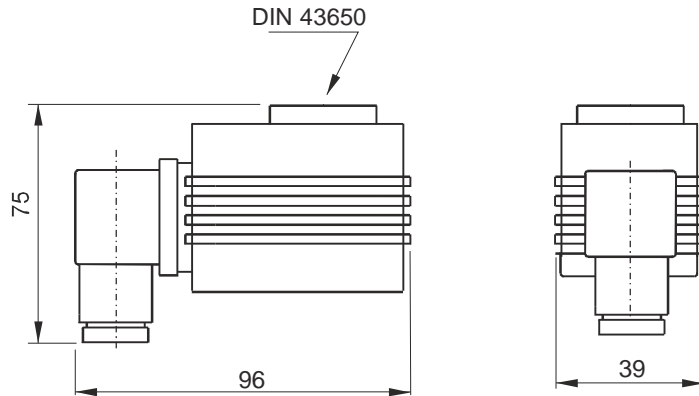
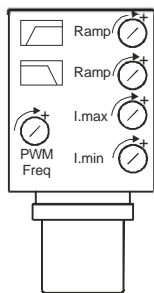

Weight: 0,11 Kg

Main features

Supply voltage	12 / 24VDC
Voltage input signal range	0 - 10 V
Input impedance	100 kohm
Max current range	2,5A
Electric connection	DIN 43650-A / ISO 4400
Ramp adjustment (independent)	0 ÷ 3 s
PWM (optionally adjustable)	120 Hz (50 ÷ 400 Hz)
Working temperature	-10 ÷ +50 °C
Normatives	EN50081-1/EN50082-2 (89/336 CEE electromagnetic comp.) 73/23/CEE / 96/68/CEE (low voltage)

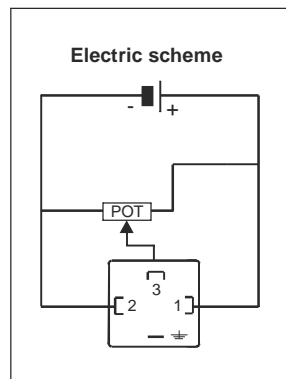

Spare part code

VPC	Electronic amplifier for solenoid valves
00	Options

Suitable for:
 - CSPC15**** (see table U040.20.15.00)
 - VMPC2**** (see table U040.20.14.00)

Instruction for use:

- 1) turn completely "I MIN" trimmer in counterclockwise direction;
- 2) adjust the external voltage input signal to the initial regulating (flow or pressure) value;
- 3) turn "I MIN" trimmer in clockwise direction until valve starts regulating;
- 4) adjust the external voltage input signal to the max value and adjust "I MAX" trimmer until the valve regulates the maximum flow or pressure on the hydraulic system.

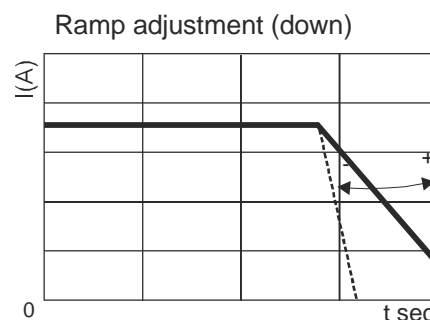
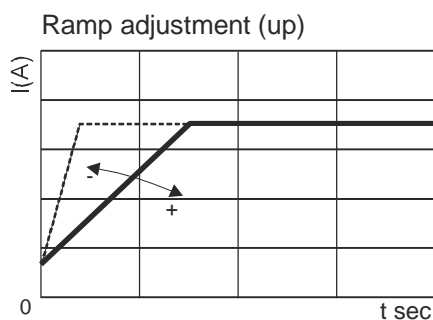

PLUGS

<p>Weight: 0,066 Kg</p>	<p>Hydraulic symbol</p> <p>Spare part code</p> <p>E70100005</p>	<p>PPC assembly code</p> <p>G</p> <p>Mounting cavities</p> <table border="1"> <tr><td>0</td><td>1</td></tr> <tr><td>2</td><td>3</td><td>4</td></tr> <tr><td>5</td><td>6</td><td>7</td><td>8</td></tr> </table>	0	1	2	3	4	5	6	7	8
0	1										
2	3	4									
5	6	7	8								
<p>Weight: 0,047 Kg</p>	<p>Hydraulic symbol</p> <p>Spare part code</p> <p>E70100003</p>	<p>PPC assembly code</p> <p>H</p> <p>Mounting cavities</p> <table border="1"> <tr><td>0</td><td>1</td></tr> <tr><td>2</td><td>3</td><td>4</td></tr> <tr><td>5</td><td>6</td><td>7</td><td>8</td></tr> </table>	0	1	2	3	4	5	6	7	8
0	1										
2	3	4									
5	6	7	8								
<p>Weight: 0,045 Kg</p>	<p>Hydraulic symbol</p> <p>Spare part code</p> <p>E70100006</p>	<p>PPC assembly code</p> <p>P</p> <p>Mounting cavities</p> <table border="1"> <tr><td>0</td><td>1</td></tr> <tr><td>2</td><td>3</td><td>4</td></tr> <tr><td>5</td><td>6</td><td>7</td><td>8</td></tr> </table>	0	1	2	3	4	5	6	7	8
0	1										
2	3	4									
5	6	7	8								
<p>Weight: 0,027 Kg</p>	<p>Hydraulic symbol</p> <p>Spare part code</p> <p>E70100004</p>	<p>PPC assembly code</p> <p>L</p> <p>Mounting cavities</p> <table border="1"> <tr><td>0</td><td>1</td></tr> <tr><td>2</td><td>3</td><td>4</td></tr> <tr><td>5</td><td>6</td><td>7</td><td>8</td></tr> </table>	0	1	2	3	4	5	6	7	8
0	1										
2	3	4									
5	6	7	8								
<p>Weight: 0,042 Kg</p>	<p>Hydraulic symbol</p> <p>Spare part code</p> <p>E70100002</p>	<p>PPC assembly code</p> <p>N</p> <p>Mounting cavities</p> <table border="1"> <tr><td>0</td><td>1</td></tr> <tr><td>2</td><td>3</td><td>4</td></tr> <tr><td>5</td><td>6</td><td>7</td><td>8</td></tr> </table>	0	1	2	3	4	5	6	7	8
0	1										
2	3	4									
5	6	7	8								
<p>Weight: 0,110 Kg</p>	<p>Hydraulic symbol</p> <p>Spare part code</p> <p>E70100010</p>	<p>PPC assembly code</p> <p>XP</p> <p>Mounting cavities</p> <table border="1"> <tr><td>0</td><td>1</td></tr> <tr><td>2</td><td>3</td><td>4</td></tr> <tr><td>5</td><td>6</td><td>7</td><td>8</td></tr> </table>	0	1	2	3	4	5	6	7	8
0	1										
2	3	4									
5	6	7	8								

Note: cavities 3, 4 and 6 are present on central manifold type UB only.

TANKS

Squared steel tanks from 3 to 30 l



Round steel tanks from 1,5 to 12 l, for horizontal and vertical mounting



Squared plastic tanks, from 1,5 to 12 l, for horizontal or vertical mounting



Round plastic tanks with 5 or 9 l volume, for horizontal or vertical mounting.



Better plastic or steel tanks?

Plastic tanks have several advantages. Among them they do not get rust, the oil level is visible, they do not damage if getting bumped, ... On the other hand steel tanks are to be preferred in case of ultra high or ultra low temperatures. They are the only choice for volumes of 12 l.

Is it possible to realize custom made tanks?

Yes. We can provide an adaptor flange (F80000001) which can be welded on custom made tanks, at customer care.

How do I order spare tanks?

Tanks can be ordered without accessories just by adding a J in front of the relevant code (es. JE60303015 instead of E60303015). When ordered with the normal code (e.g. E60303015) they include the relevant accessories such as: plugs, filler breather, oil level, fixing devices, ... depending on the kind of tank. Tanks specified in PPC speaking code always include all relevant accessories.

ROUND STEEL TANKS A & B SERIES



Recommended tightening torque for 1/2" BSPP: 5 Nm

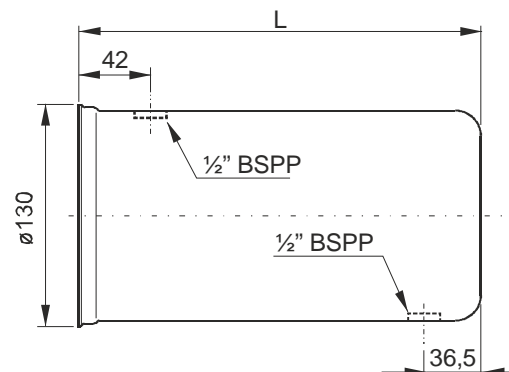

Description	PPC assembly code	Spare part code	L (mm)	Weight	Actual filling volume (lt)	
					Horizontal	Vertical
1,5 l cylindrical horizontal / vertical mounting	1,5A / 1,5AV	E60303001	150	0,78 Kg	1,8	1,2
2,5 l cylindrical horizontal / vertical mounting	2,5A / 2,5AV	E60303004	235	1,04 Kg	2,8	2,3



Recommended tightening torque for 1/2" BSPP: 5 Nm

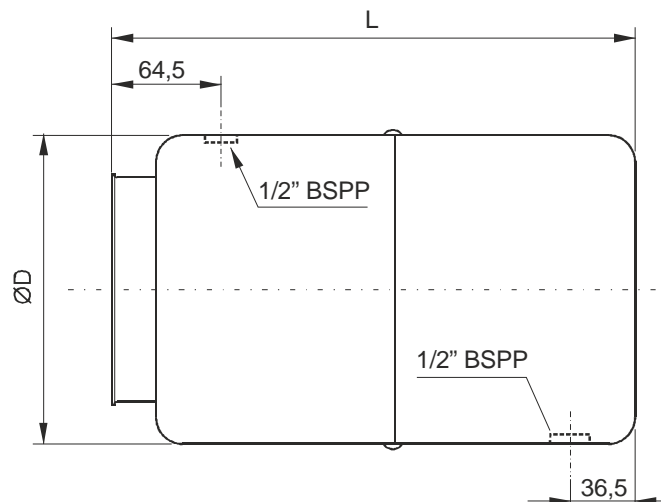

Description	PPC assembly code	Spare part code	L (mm)	ØD (mm)	Weight	Actual filling volume (lt)	
						Horiz.	Vert.
5 l cylindrical horizontal / vertical mounting	5B / 5BV	E60303006	300	180	1,82 Kg	6,5	4,9
10 l cylindrical horizontal / vertical mounting	10B / 10BV	E60303011	262	220	2,01 Kg	8,4	6,0
12 l cylindrical horizontal / vertical mounting	12B / 12BV	E60303012	380	220	2,47 Kg	12,6	10,5

All measures are indicative in mm

Material	Fe P04-EN10130 steel sheet 1,5mm thickness
Fluid	Mineral based oil ISO/DIN 6743/4
Working temperature	-15 / +70°C

Note: the piping kit, standard suction filter, filler/breather and discharge plug are included when specifying the tank in PPC assembly code. When ordering spare parts, only the discharge plug and filler/breather are included.

HORIZONTAL/VERTICAL SQUARE WELDED STEEL TANKS C SERIES

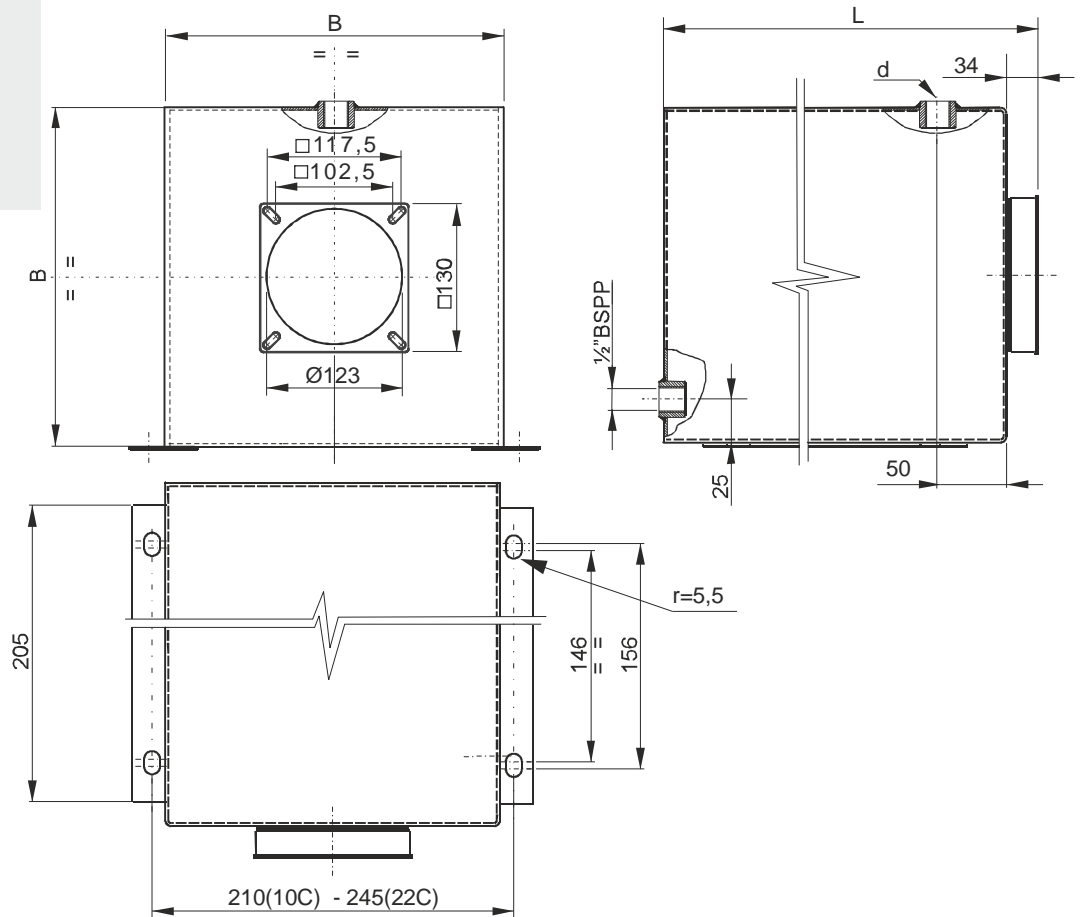

Description	PPC assembly code	Spare part code	L (mm)	B (mm)	d	Weight	Actual filling volume (lt)	
							Horizont.	Vertical
10 l squared horiz./vert. mounting	10C / 10CV	E60303042	330	185	½" BSPP	5,50 Kg	9,6	8,1
22 l squared horiz./vert. mounting	22C / 22CV	E60303044	470	223	¾" BSPP	6,80 Kg	20,6	18,5

All measures are indicative in mm

Material	Fe P04-EN10130 steel sheet 1,5mm thickness
Fluid	Mineral based oil ISO/DIN 6743/4
Working temperature	-15 / +70°C

Notes: the piping kit, standard suction strainer, filler/breather and discharge plug are included when specifying the tank in PPC assembly code.
When ordering spare tanks, only the discharge plug and filler/breather are included.

On request special square welded tanks can be realized. An inquiry must be sent to our technical department with indication of quantities.

SMALL SIZE SQUARE WELDED STEEL TANKS E SERIES

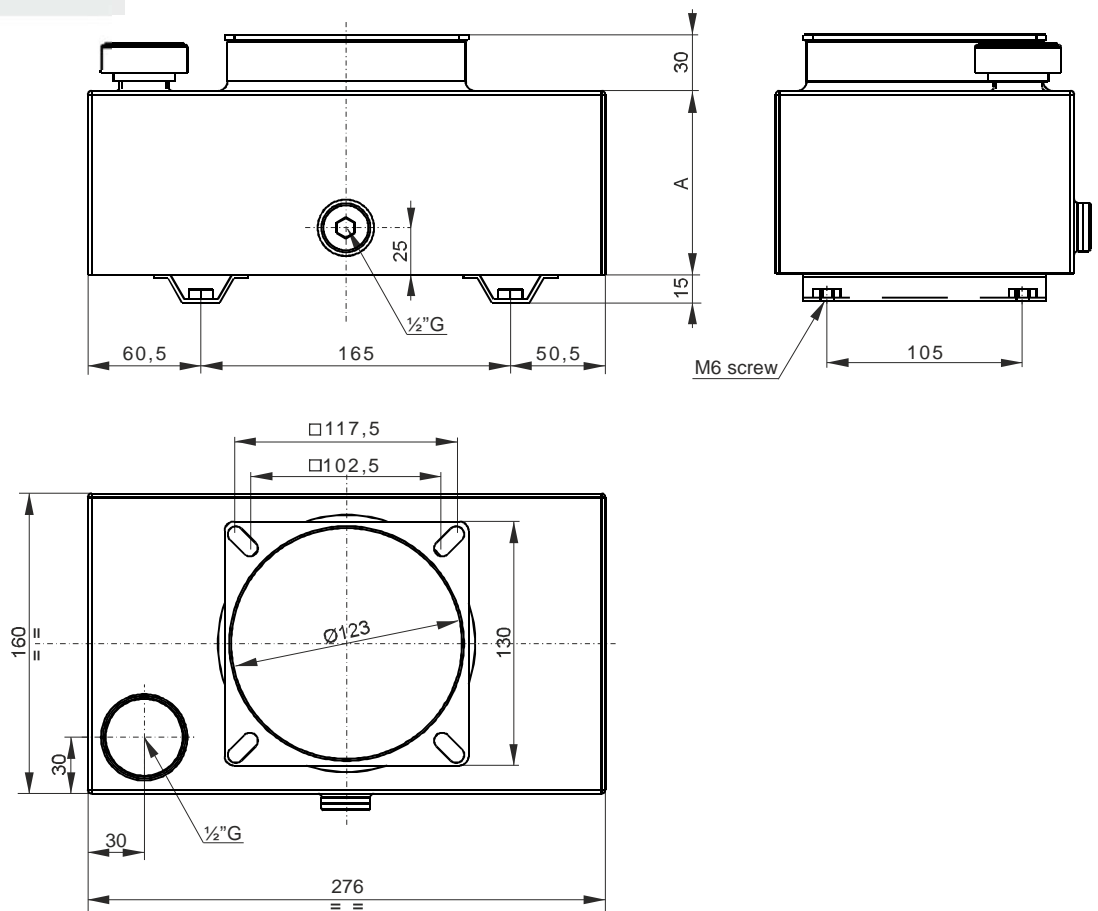

Description	PPC assembly code	Spare part code	A	Weight	Actual filling volume (lt)	
					Horizontal	Vertical
3 l square vertical mounting	3EV	E60303053	98 mm	3,09 Kg	-	4,2
7 l square vertical mounting	7EV	E60303057	190 mm	4,32 Kg	-	8,3

All measures are indicative in mm

Material	Fe P04-EN10130 steel sheet 1,5mm thickness
Fluid	Mineral based oil ISO/DIN 6743/4
Working temperature	-15 / +70°C

Notes: the piping kit, standard suction strainer, filler/breather and discharge plug are included when specifying the tank in PPC assembly code.
When ordering spare tanks, only the discharge plug and filler/breather are included.

SMALL SIZE SQUARE WELDED STEEL TANKS E SERIES

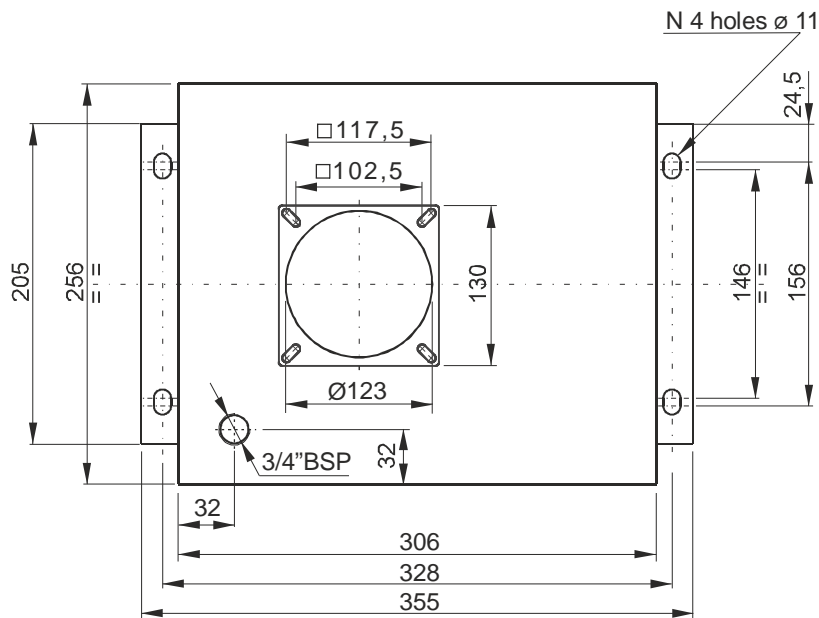
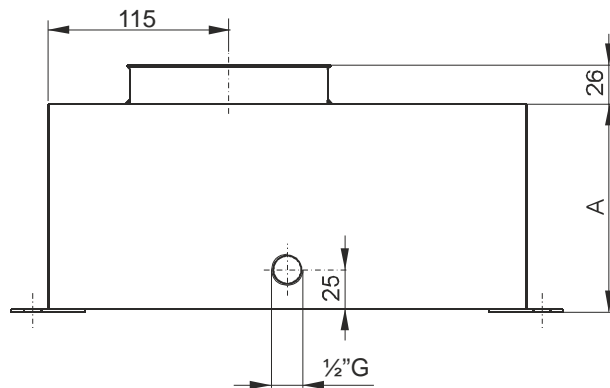

Description	PPC assembly code	Spare part code	A	Weight	Actual filling volume (lt)	
					Horizontal	Vertical
8 l square vertical mounting	8EV	E60303041	133 mm	4,50 Kg	-	10,4
15 l square vertical mounting	15EV	E60303014	237 mm	5,20 Kg	-	18,5

All measures are indicative in mm

Material	Fe P04-EN10130 steel sheet 1,5mm thickness
Fluid	Mineral based oil ISO/DIN 6743/4
Working temperature	-15 / +70°C

Notes: the piping kit, standard suction strainer, filler/breather and discharge plug are included when specifying the tank in PPC assembly code.

When ordering spare tanks, only the discharge plug and filler/breather are included.

SQUARE WELDED STEEL TANKS E SERIES

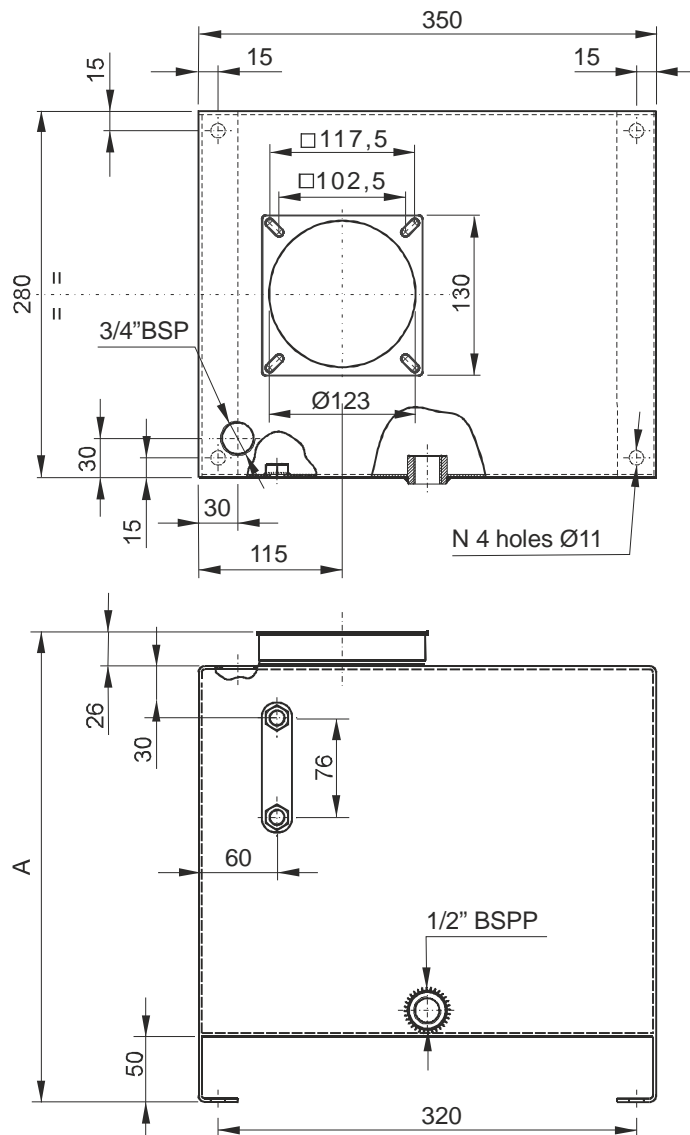

Description	PPC assembly code	Spare part code	A	Weight	Actual filling volume (lt)	
					Horizontal	Vertical
20 l squared vertical mounting	20EV	E60303015	293 mm	6,50 Kg	-	20,8
30 l squared vertical mounting	30EV	E60303048	423 mm	8,50 Kg	-	33,5

All measures are indicative in mm

Material	Fe P04-EN10130 steel sheet 2,5mm thickness on top and side, 1,5mm thickness front and rear
Fluid	Mineral based oil ISO/DIN 6743/4
Working temperature	-15 / +70°C

Notes: the piping kit, standard suction strainer, filler/breather, level gauge and discharge plug are included when specifying the tank in PPC assembly code.

When ordering spare tanks, only the discharge plug, filler/breather and level gauge are included.

On request special square welded tanks can be realized. An inquiry must be sent to our technical department with indication of quantities.

SQUARE PLASTIC TANKS L & M SERIES

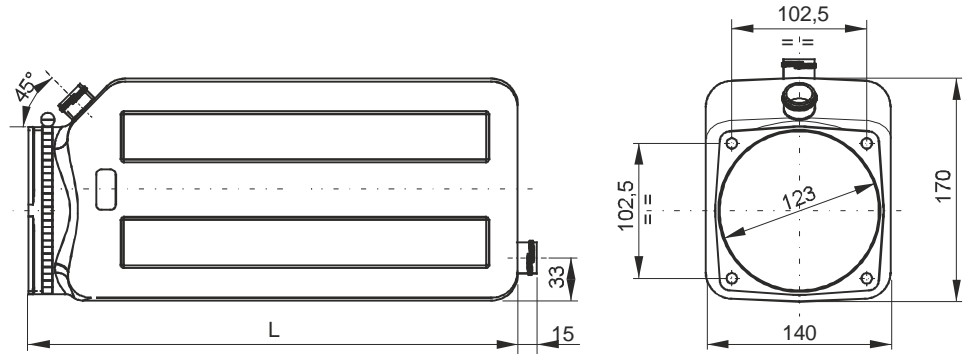

Description	PPC assembly code	Spare part code	L (mm)	Weight	Actual filling volume (lt)	
					Horizontal	Vertical
1,5 l squared horizontal / vertical mounting	1,5L / 1,5LV	H60303016	135	0,32 Kg	2,4	1,5
3 l squared horizontal / vertical mounting	3L / 3LV	H60303018	250	0,42 Kg	4,4	4,2
6 l squared horizontal / vertical mounting	6L / 6LV	H60303020	350	0,63 Kg	6,2	6,6

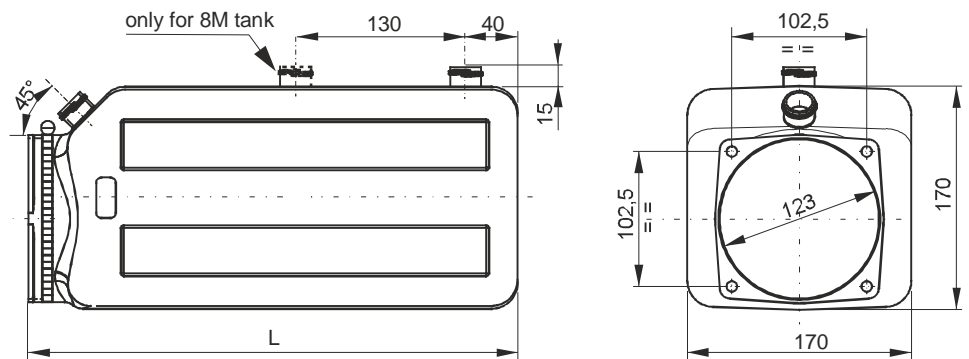

Description	PPC assembly code	Spare part code	L (mm)	Weight	Actual filling volume (lt)	
					Horizontal	Vertical
5 l squared horizontal / vertical mounting	5M / 5MV	H60303025	270	0,60 Kg	5,8	5,7
8 l squared horizontal / vertical mounting	8M / 8MV	H60303033	375	0,76 Kg	8,1	8,8

Material	PE-HD neutral / transparent color (DO NOT EXPOSE TO DIRECT SUNLIGHT)
Fluid	Mineral based oil ISO/DIN 6743/4
Working temperature	-15 / +70°C

Notes: the piping kit, standard suction strainer and filler/breather are included when specifying the tank in PPC assembly code. When ordering spare tanks, only the filler/breather C86100003, C86200002 or C86100001 and clamp band are included. Discharge ports are normally blind moulded.

PLASTIC TANKS N & P SERIES

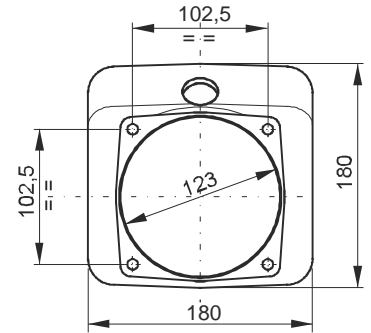
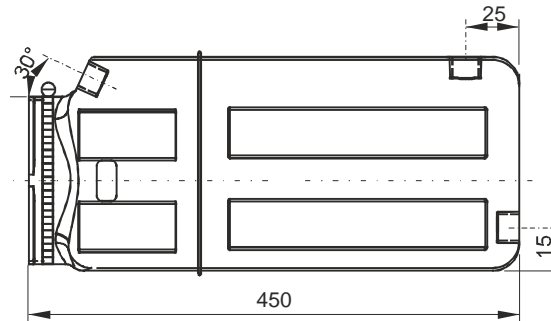

Description	PPC assembly code	Spare part code	Weight	Actual filling volume (lt)	
				Horizontal	Vertical
12 I squared horizontal / vertical mounting	12N / 12NV	H60303036	0,94 Kg	12,6	12,1

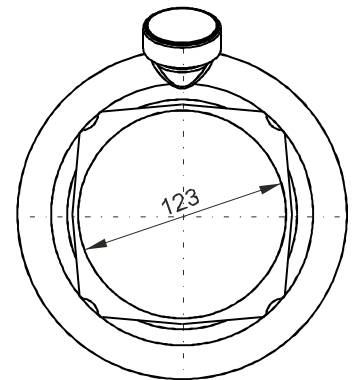
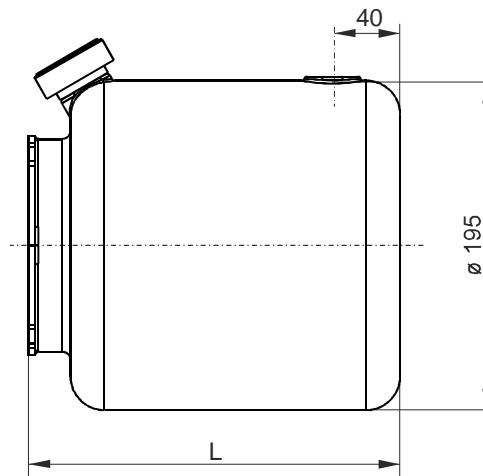

Description	PPC assembly code	Spare part code	L (mm)	Weight	Actual filling volume (lt)	
					Horizontal	Vertical
5 I round horizontal / vertical mounting	5P / 5PV	H60303028	219	0,60 Kg	5,9	4,8
9 I round horizontal / vertical mounting	9P / 9PV	H60303031	323	0,76 Kg	8,7	7,8

Material	PE-HD neutral / transparent color (DO NOT EXPOSE TO DIRECT SUNLIGHT)
Fluid	Mineral based oil ISO/DIN 6743/4
Working temperature	-15 / +70°C

Notes: the piping kit, standard suction strainer and filler/breather are included when specifying the tank in PPC assembly code. When ordering spare tanks, only the filler/breather C86100003, C86200002 or C86100001 and clamp band are included. Discharge ports are normally blind moulded.

TANKS PLUGS AND ACCESSORIES

Filler breather
1/2" - 3/4" BSPP

	1/2"	3/4"
A	1/2"	3/4"
ø B	30	47
C	10	17
D	21	17

Suitable for B/BV type tanks (1/2" BSPP)
Suitable for EV type tanks (3/4" BSPP)

Spare part codes

C86100001 (1/2" BSPP)
C86100002 (3/4" BSPP)

Drain plug

	A
TCNB0800	15
TB050801	19

Suitable for all steel tanks

Spare part codes

Code: TCNB0800 (plastic)
TB050801 (steel)

Filler breather slip-in

Suitable for all plastic tanks

Spare part code

C86200002

Filler breather
3/4" BSPP female

Suitable for all series plastic tanks

Spare part code

C86100003

3/4" BSPP female
drain plug

Suitable for all series plastic tanks

Spare part code

E60513005

90° elbow for suction pipe
M 1/4" & 3/8" BSPT - M 3/8" BSPP
Recommended for horizontal tanks

Filter not included in the code

	L	D
PP01E40	40	1/4"BSPT
PP01E77	77	1/4"BSPT
PP02E40	40	3/8"BSPT
PP02E77	77	3/8"BSPT

Spare part code

PP0*E**

3/8" suction pipe

	L
PP0242	42
PP0268	68
PP02125	125
PP02142	142
PP02165	165
PP02180	180
PP02190	190
PP02237	237
PP02370	370

To fit inlet strainers C34100005 to the pump

Spare part codes

PP02**

1/4" return/suction pipe

	L
PP0141	41
PP01123	123
PP01370	370

Recommended as suction pipe for PMC02 hand pumps and as return pipe with C34200001 return filter.

Spare part codes

PP01**

ACCESSORIES

Inlet strainers
Screened eccentric type

Filtration degree: 90 micron

Recommended for 1,5 l tanks horizontal mounting

Weight: 0,13 Kg

Spare part code

C34100001

Standard inlet strainer filters
Filtration degree: 90 micron

	D
C34100004	1/4" BSPP
C34100005	3/8" BSPP

Weight: 0,013 Kg

Spare part codes

C3410000*

Steel tank adapter

Unpainted, to be welded on custom made tanks

Weight: 0,21 Kg

Spare part code

F80000001

Return filter

Suitable for all tanks over 3l

Weight: 0,13 Kg

Filtration degree: 90 micron

Spare part code

C34200001

Relief valve return diffuser
To be mounted in cavity Tr

to be fitted in 1/4" BSPP

It reduces foam and noise when relief valve is laminating.

Recommended for all vertical mounting tanks.

Spare part code

SFEP01D

90° adapter for vertical tanks

Spare part code

E60513004

Flexible plastic pipe

Recommended as standard return pipe.

To be fixed with TR01-12 and cut at proper length.

To be ordered in meters

Spare part code

SF12

Flexible plastic pipe holder for return line
1/4" BSPT

Spare part code

TR0112

EXTERNAL MANIFOLDS & ACCESSORIES

Standard NG6 (cetop 3) base modular manifold blocks with parallel or series connections, rear or lateral ports. They can be stacked one upon the other. Top manifold P and T ports can be plugged with simple 1/4" or 1/8" BSP plugs.

Piloted operated check valves can be integrated within a modular manifold block for NG6 (cetop 3) valves, thus avoiding the extra modular cetop 3 sandwich type valve between the base block and the spool valve.

The external bulk 8,8 cc/stroke hand pump can be fitted under NG6 (cetop) 3 modular manifolds. An easy way to add an «emergency» functionality to the power pack. The lever can be rotated 360°.



The spin-on type return filter is mounted in a modular manifold which can be stacked under NG6 (cetop 3) modular manifolds

The PPC to SD01 stackable valves converter lets you mount our range of modular stackable valves, an up-to-date and lightweight alternative to NG6 (cetop3) directional valves



A full set of accessories is available to complete the power pack configuration



The NG3 MICRO set of blocks and valves is a ultracompact and cost effective alternative to NG6 (cetop3), up to 15 l/min. They can be mounted thanks to the PPC to PPM adaptor



How many types of external manifold blocks can be mounted?

The central manifold exit face allows the mounting of two different block systems, fixed by 2x M8 bolts (normally used for cetop3 modular manifolds stacks) or 4x M6 bolts systems (for modular manifolds for cartridge valves). The two bolt systems cannot be mixed on the same stack. For every product code the fixing system type is clearly displayed in following tables. To mount stackable directional valves or NG3 MICRO directional valves a relevant adaptor plate is required. See section G for the relevant valves details.

When do I need to mount the spacer block 28mm?

Whenever a big motor is mounted on the power pack. Normally the E60403004 spacer must be mounted below the stack of cetop3 blocks with AC motors with frame 80 or higher and with DC motors with frame 125 or higher.

When are the modular manifolds for differential area cylinders used?

With UR central manifolds, for reversible pumps circuits, the exit port are A and B, instead of P and T as usual. With differential area cylinders, when the bidirectional pump flow is outputting to B port, there will be more flow returning to A port, connected to the piston side of the cylinder, than that going to B port, connected to the rod side, due to the cylinder different area ratio. This block function is to discharge to tank the extra flow generated, which cannot be absorbed by the pump itself.

EXTERNAL MANIFOLDS & VALVES MOUNTING EXAMPLES

PPC + SD01 STACKABLE VALVES

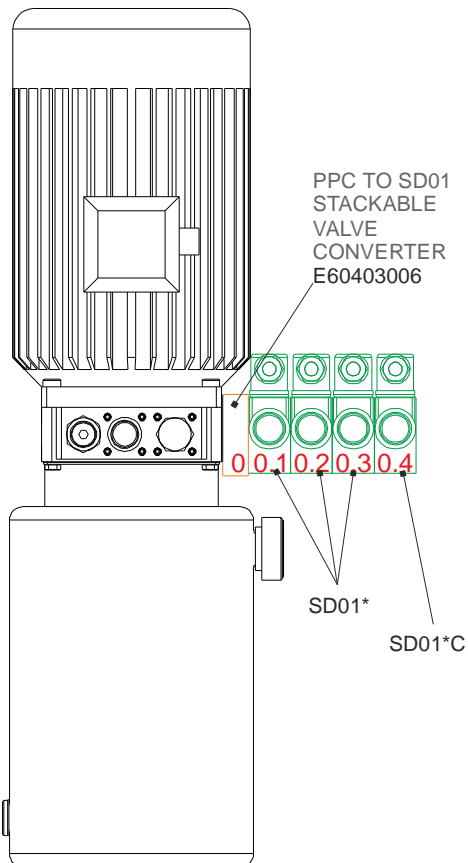

PPC + NG3 MICRO BLOCKS & VALVES

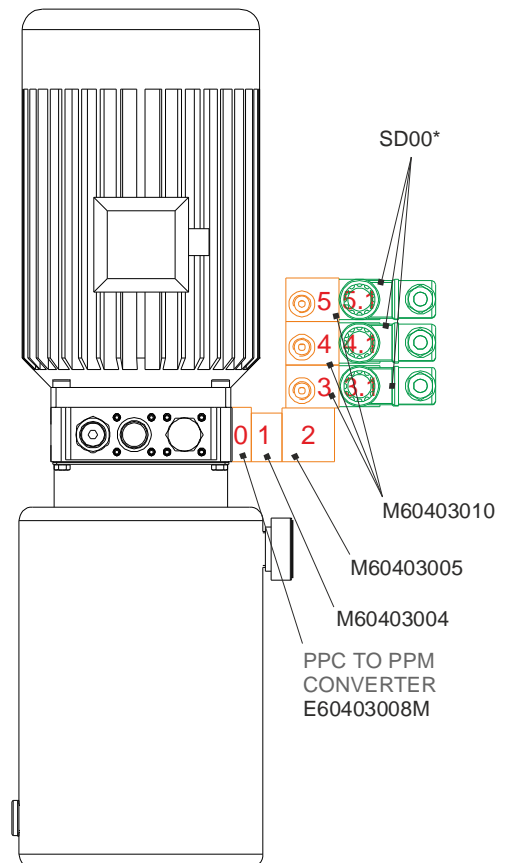

PPC + NG6 (CETOP 3) BLOCKS & VALVES

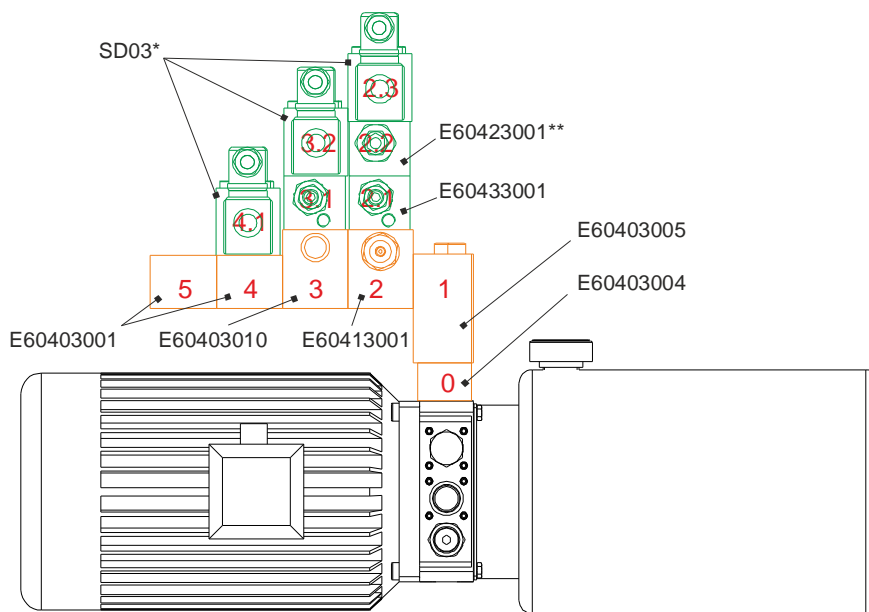

The mini powerpacks external manifolds and valves are arranged following a stack levels logic. Each stack is numbered as n, n.1, n.2, n.3,... where n is the basic manifold stack number, n.1 is the first valve mounted on top of manifold n, n.2 is the second one mounted on top of n.1,... See above self-explanatory drawings where manifolds are coloured in orange and valves in green. Stack levels are numbered in red.

NG6 (CETOP 3) MODULAR MANIFOLDS. REAR PORTS

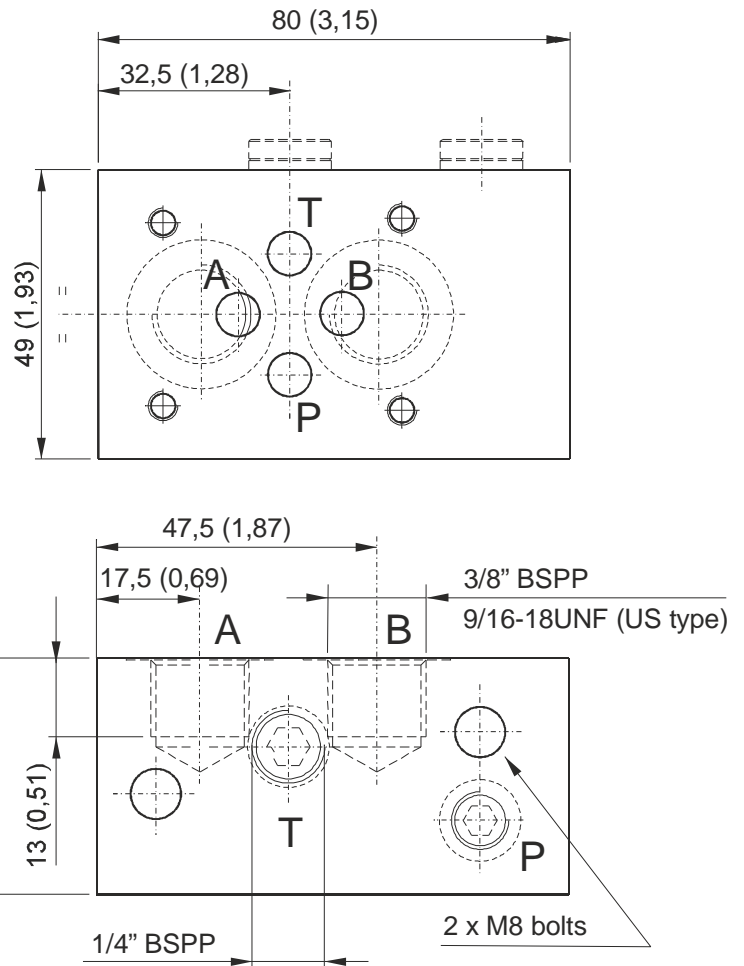

measures in mm (inches)
 Weight: 0,37 kg (0,82lb)
 Fixing system: 2 x M8 tie-rods
 steel class 8.8 or above

Parallel connection	Spare part code
Rear ports	E60403001
Rear ports US execution	E60403001US

Note: to add external manifolds to PPC assembly code, just add their spare part codes at the end of PPC code. Ex: PPC-0,8 12DC-UA-J-G1,1-D/280-G-1,5L+E60403004+E60403010

The Cetop attachment is on motor side. With AC motor frames bigger than 71, always add a spacer manifold E60403004 (see next page) below the Cetop manifold to avoid interference between the Cetop valve and the motor.

Recommended tightening torque for M8 bolts: 16 Nm

NG6 (CETOP 3) MODULAR MANIFOLDS. LATERAL PORTS

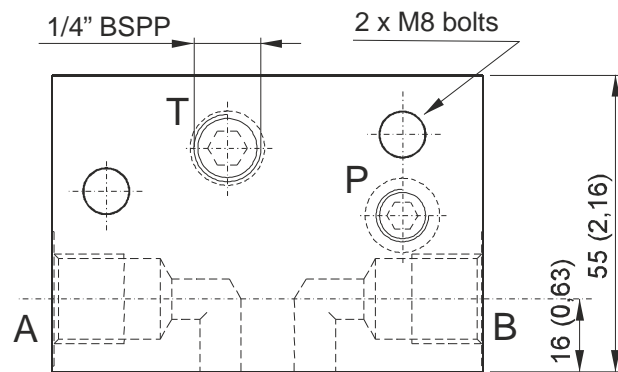
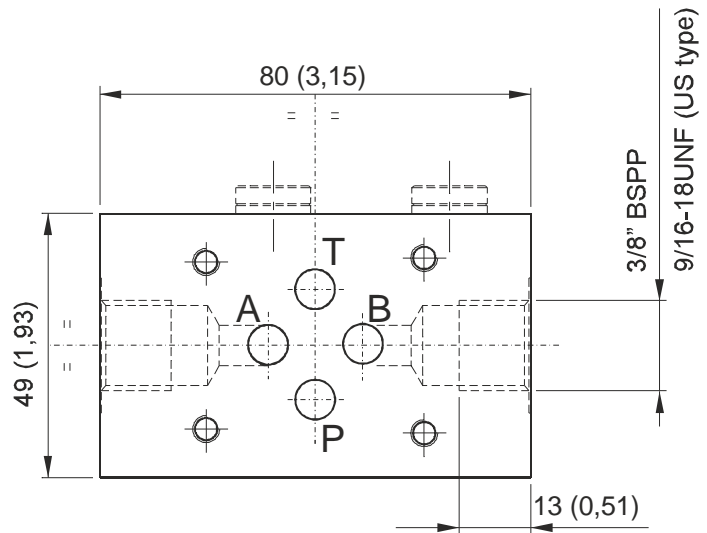

measures in mm (inches)
 Weight: 0,56 kg (1,2lb)
 Fixing system: 2 x M8 tie-rods
 steel class 8.8 or above

Option P port:
 P port for modular blocks

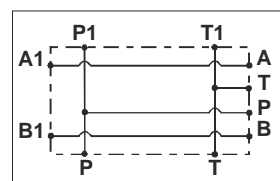

<i>Parallel connection</i>	Spare part code
Lateral ports	E60403010
Lateral ports US execution	E60403010US

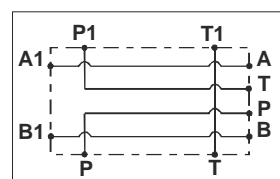

<i>Serial connection</i>	Spare part code
Lateral ports	E60403011
Lateral ports US execution	E60403011US

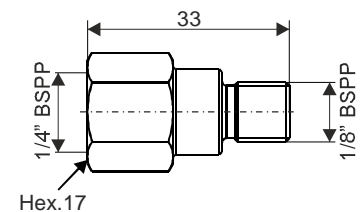

Note: to add external manifolds to PPC assembly code, just add their spare part codes at the end of PPC code. Ex: PPC-0,8 12DC-UA-J-G1,1-D/280-G-1,5L+E60403004+E60403010

The Cetop attachment is on motor side. With AC motor frames bigger than 71, always add a spacer manifold E60403004 (see next page) below the Cetop manifold to avoid interference between the Cetop valve and the motor.

Recommended tightening torque for M8 bolts: 16 Nm

NG6 (CETOP 3) MODULAR MANIFOLDS WITH INTEGRAL PILOT OPERATED CHECK VALVES

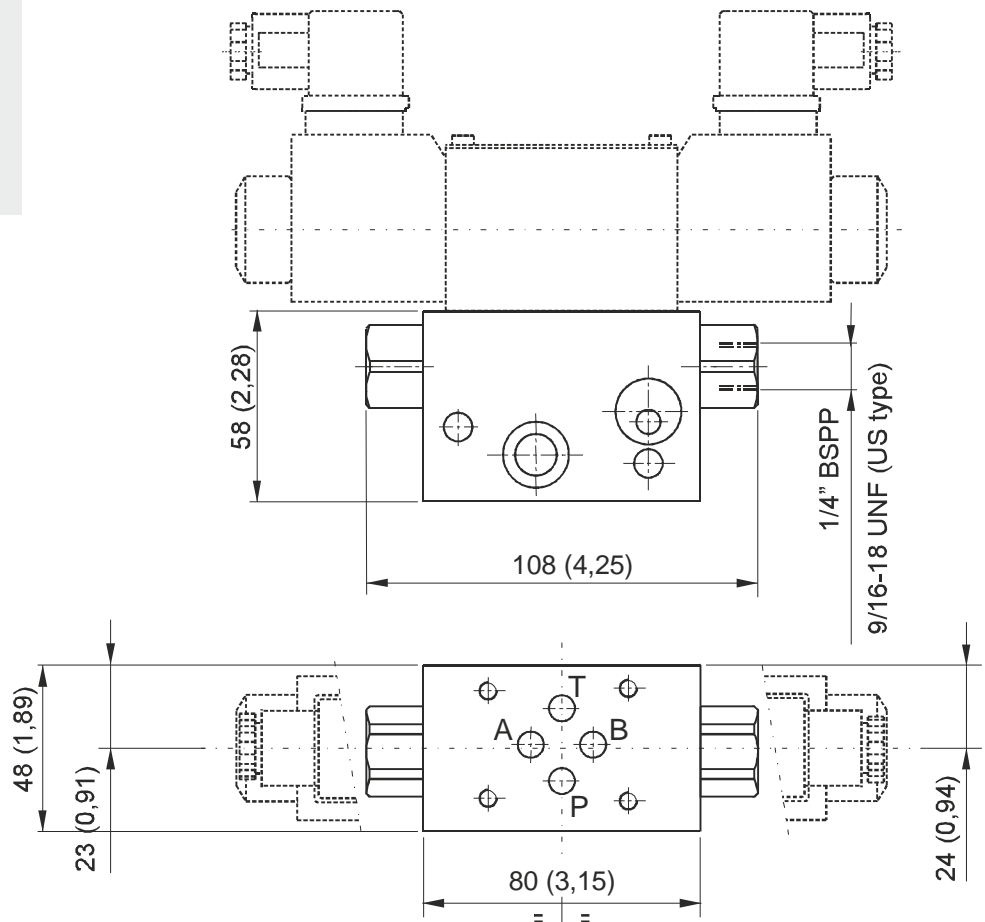

measures in mm (inches)

Main features

Weight	0,71 Kg
Fixing system	2 x M8 tie-rods steel class 8.8 or above

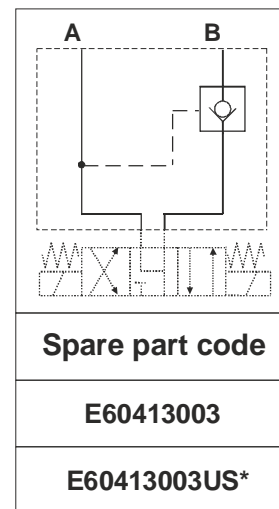
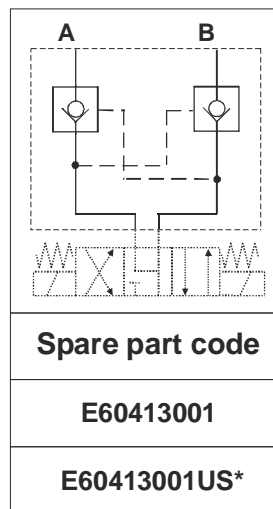
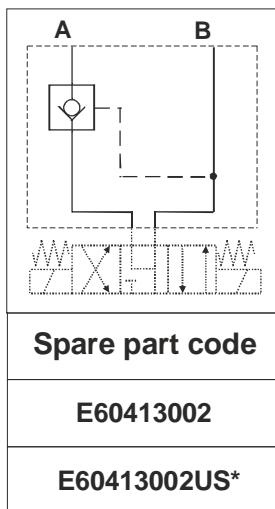

*: US execution with 9/16-18UNF SAE06 exit ports
Code does not include the Cetop solenoid valve.
Recommended tightening torque for M8 bolts: 16 Nm

MODULAR MANIFOLD WITH PILOT OPERATED CHECK VALVES

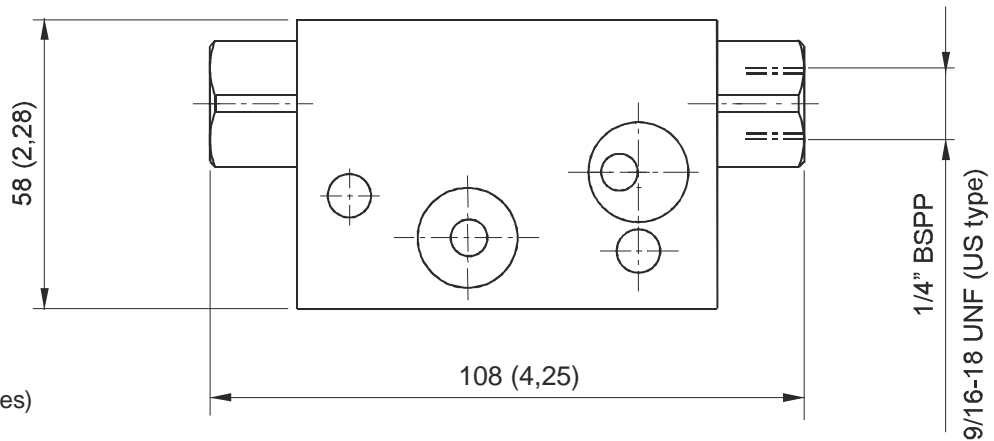

measures in mm (inches)

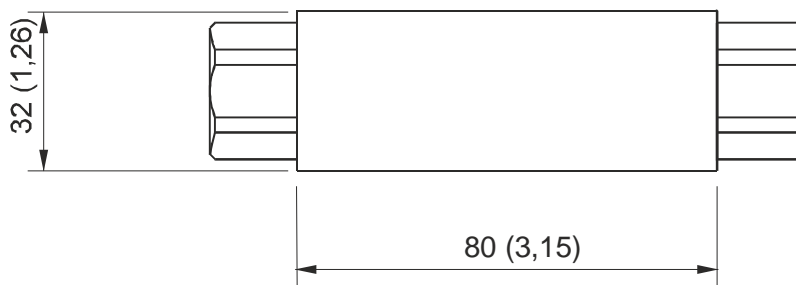

Suitable for:
U4 body
UR body

Weight: 0,5 kg

Fixing system: 2 x M8 tie-rods
steel class 8.8 or above

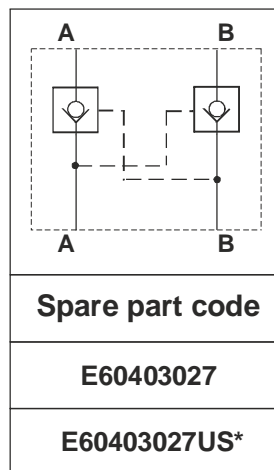

*: US execution with 9/16-18UNF SAE06 exit ports
Recommended tightening torque for M8 bolts: 16 Nm

SPACER ELEMENT



Weight: 0,23 kg

Fixing system: 2 x M8 tie-rods
steel class 8.8 or above

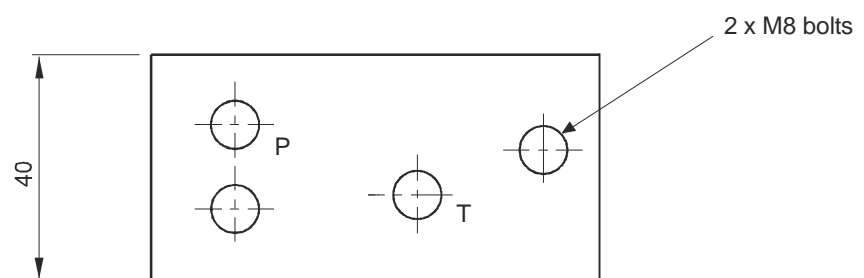
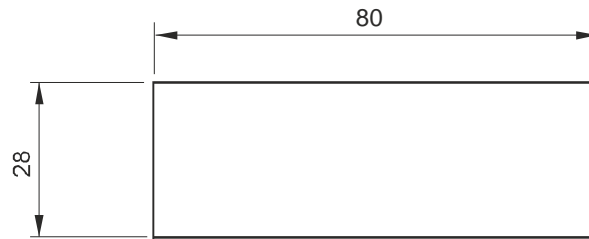

Suitable for: all central manifolds with
AC motors with frame bigger than 71
and DC motors with frame
bigger than Ø125.

Mounting example

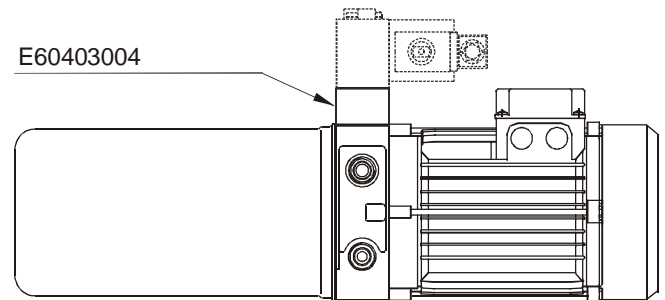

Spare part code
E60403004

90° ROTATION MANIFOLD



Weight: 0,72 kg
 Fixing system: 2 x M8 tie-rods
 steel class 8.8 or above

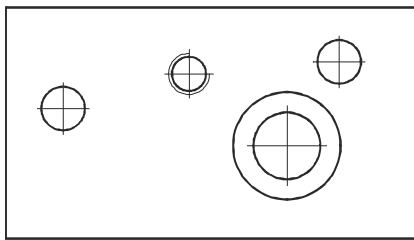
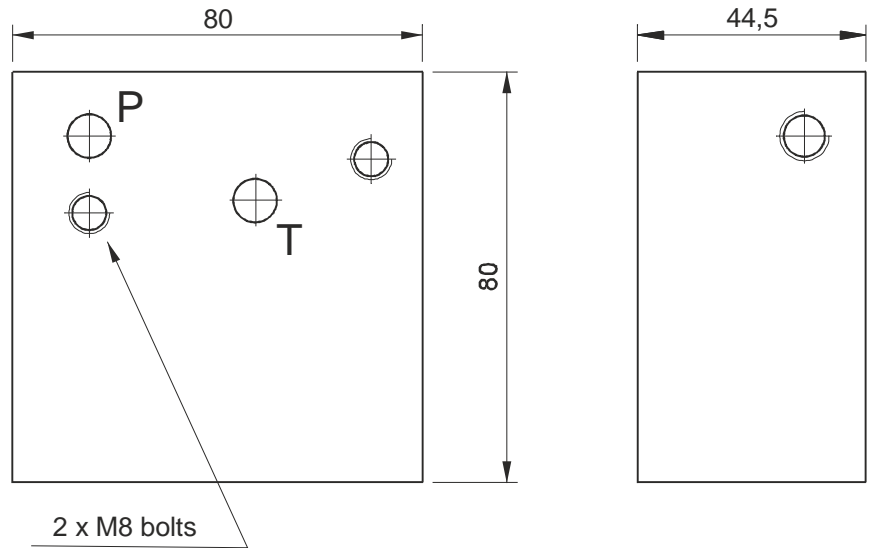

Mounting example

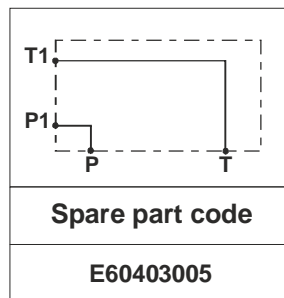
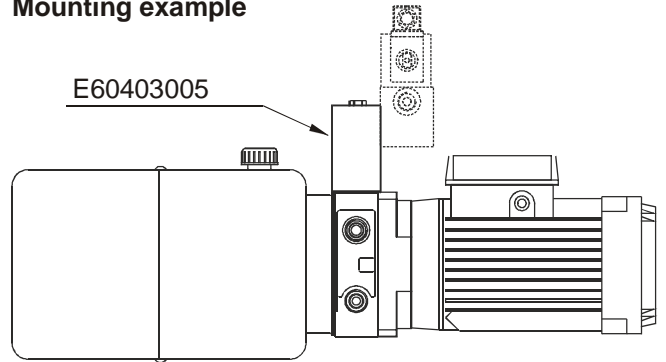

MODULAR MANIFOLD WITH CHECK VALVE FOR DIFFERENTIAL AREA CYLINDER

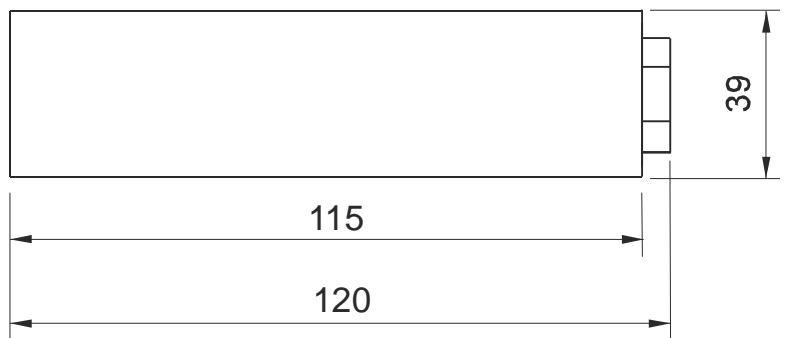
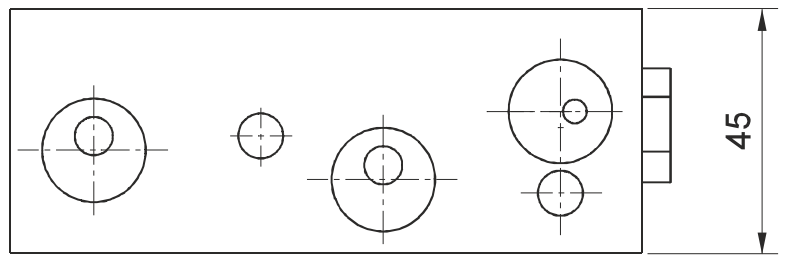

Main features

- Suitable for UR body with differential area cylinder**
- Fixing system:** PPC 2xM8 tie-rods steel class 8.8
- Tightening torque:** 16Nm
- Weight:** 0,5 kg

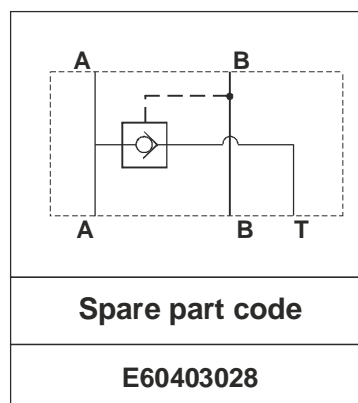

Suitable for: UR body with differential cylinders
 Fixing system: 2 x M8 tie-rods
 steel class 8.8 or above
 Notes: Recommended tightening torque for M8 bolts: 16 Nm

PM09 HAND PUMP MODULAR MANIFOLD

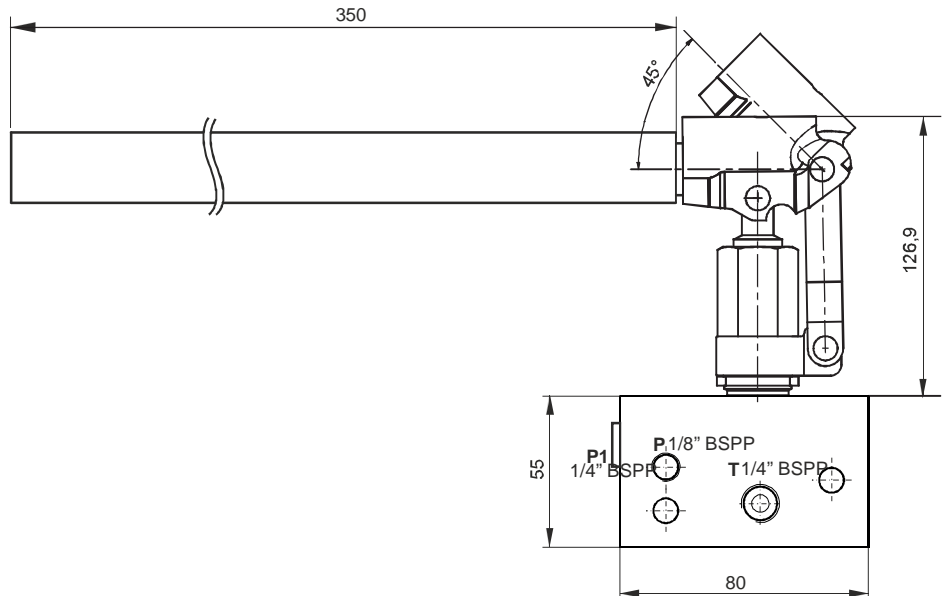

Fixing system: 2 x M8 tie-rods
Material class: min. 8.8 or equivalent

Block height: 39mm
Weight: 1,8 kg

Main features

Max pressure	210 bar
Displacement	8,8 cc/stroke
Fixing bolts	2 x M8 (8.8 class steel)
Filtration grade	25 ÷ 50 µ
Temperature range	-20 ÷ +70°C

Mounting example

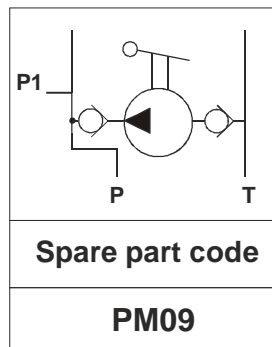
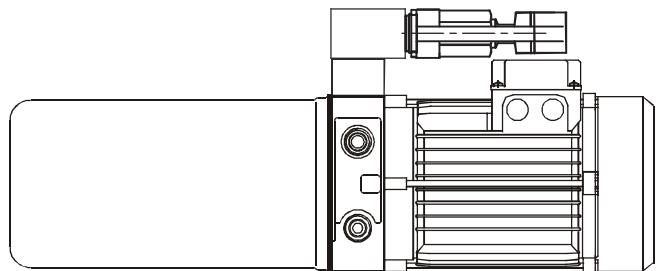

Recommended tightening torque for M8 bolts: 16 Nm.

Commissioning: the pump must be bled by opening the plug of the unused pressure port (P o P1), pumping a few times until oil comes out, then tightening the plug again.

RETURN LINE FILTER MODULAR MANIFOLD



Fixing system: 2xM8 tie-rods
steel class 8.8 or above

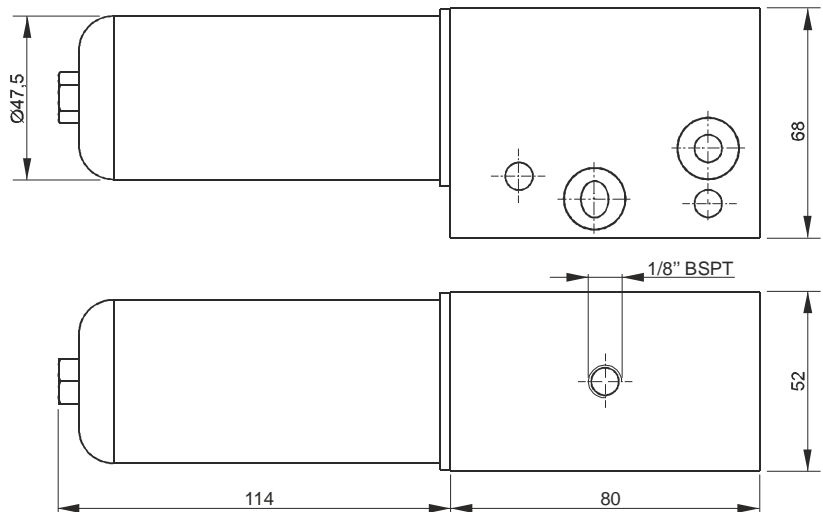

Main features

Opening valve pressure	210 bar
Max flow	20 l/min
Filtration setting	15 µ
Oil temperature	-30 ÷ + 80 °C
Weight	0,87 kg

Note: Recommended tightening torque for M8 bolts: 16 Nm

Hydraulic scheme

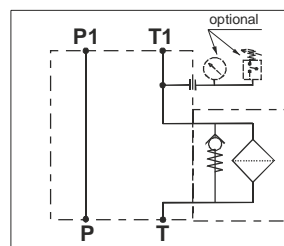

Note: standard code does not include the MIR40 pressure gauge or F4 pressure switch

Spare part code

E60403020

Modular manifold with return filter on T

Replacement cartridge part code

FO201385

Options

Pressure gauge for return filter manifold

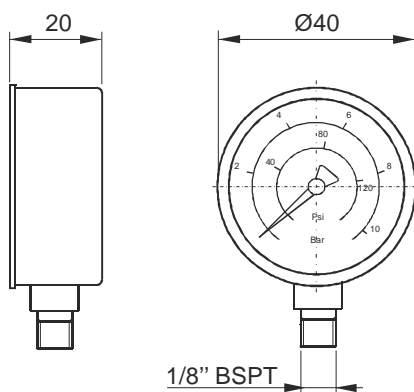

Weight: 0,1 Kg

Spare part code

MIR4010

Pressure switch for return filter manifold

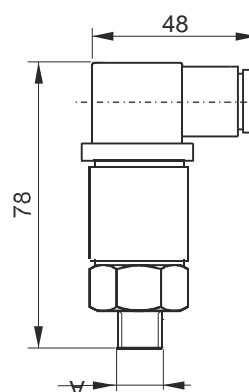

Setting range	0,2 ÷ 2,5 bar
Protection degree	IP 65
Hysteresis	10 ÷ 15 %
Weight	0,05 Kg
Max load	0,5 A at 250 VAC
Electric switch	NO/NC

	A
F4R0M3	1/8\"/>

Spare part code

F4R0M3

BASE MANIFOLD CONVERTERS



PPC TO SD01 STACKABLE VALVES CONVERTER
(needed to mount SD01 stackable valves)

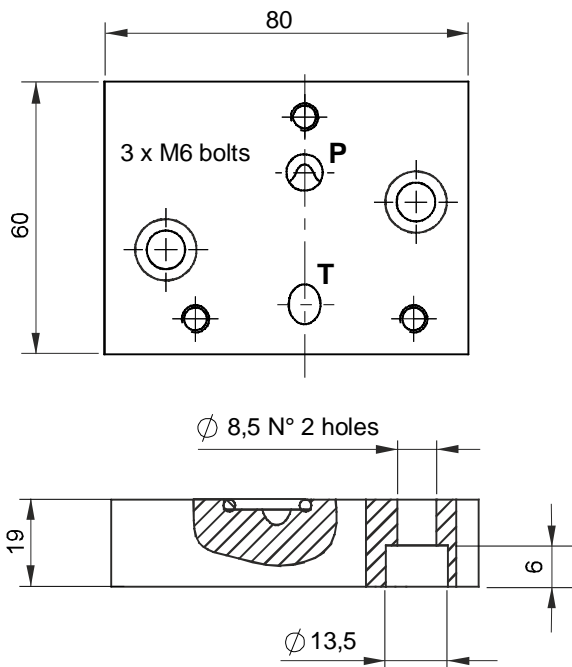

Fixing system: 2 x M8x20 steel class 8.8 or above
Weight: 0,22 Kg

Spare part code
E60403006

PPC TO PPM BASE CONVERTER
(needed to mount PPM NG3 MICRO blocks range)

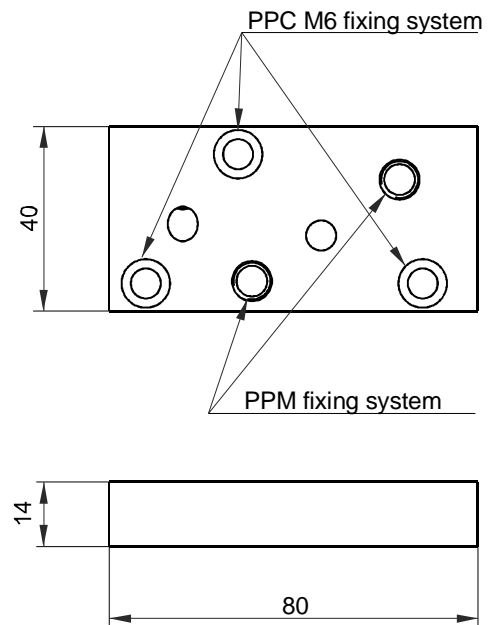

Fixing system: 3 x M6x20 steel class 8.8 or above
Weight: 0,11 Kg

Spare part code
E60403008M

PPM NG3 MICRO MODULAR MANIFOLDS. LATERAL PORTS

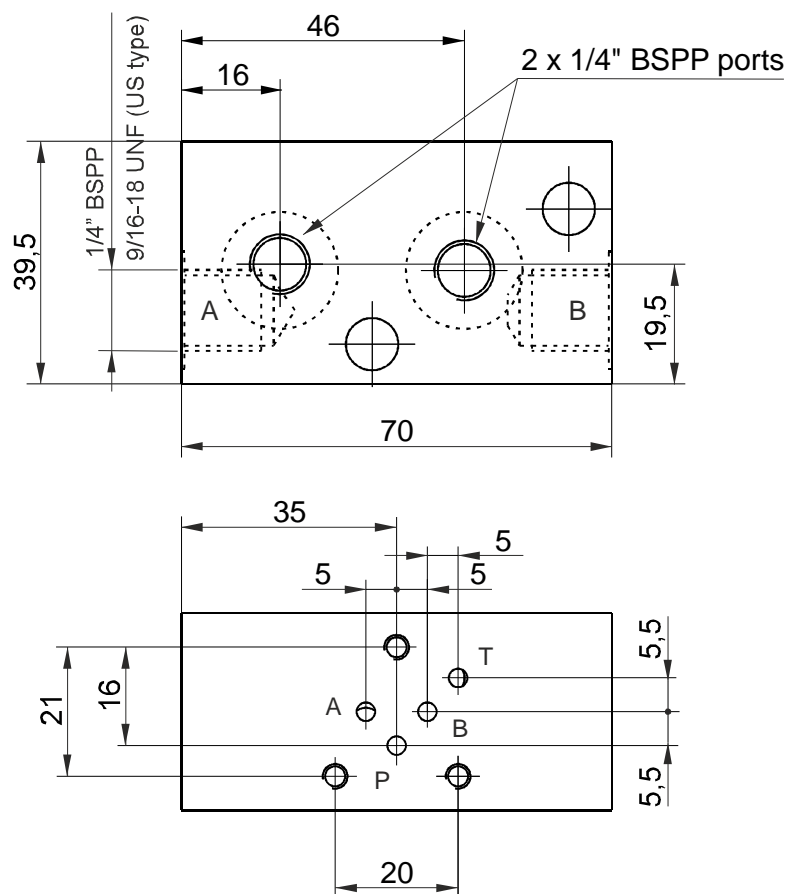

Weight: 0,21 kg
 Fixing system: 2 x M8 tie-rods
 steel class 8.8 or above

Parallel connection	Spare part code
Lateral ports	M60403010
Lateral ports US execution	M60403010US

Note: to add NG3 MICRO external manifolds to PPC a base converter assembly code, just add their spare part codes at the end of PPM code.
 Ex: PPM-0,8 12DC-MB-J-K0,6-D/280-G-1,5L+**M60403004**+**M60403010**

The NG3 micro valve attachment is on motor side.

Recommended tightening torque for M8 bolts: 16 Nm

PPM SPACER ELEMENT



Weight: 0,14 kg

Fixing system: 2 x M8 tie-rods
steel class 8.8 or above

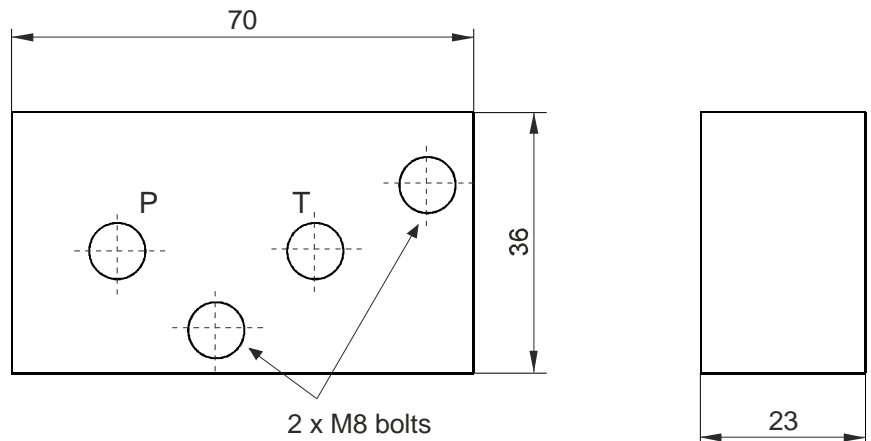

Mounting example

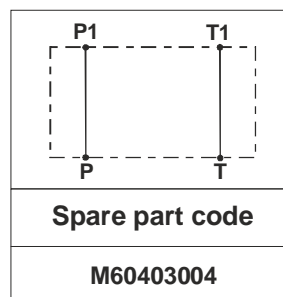
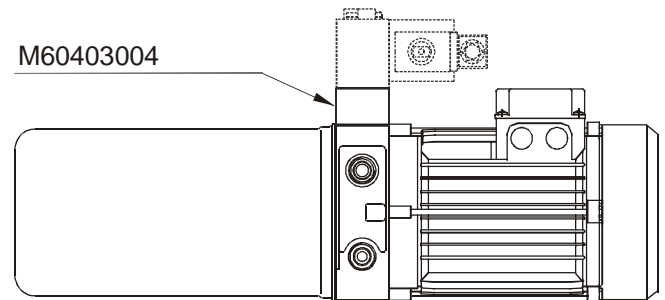

PPM 90° ROTATION MANIFOLD



Weight: 0,26 kg
 Fixing system: 2 x M8 tie-rods
 steel class 8.8 or above

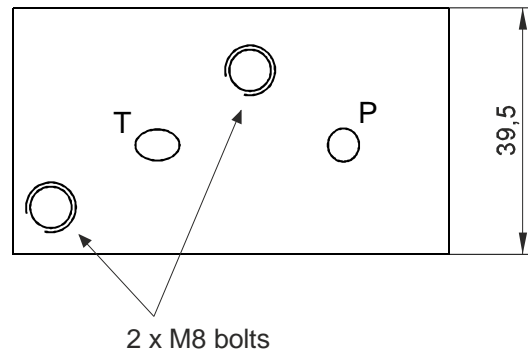
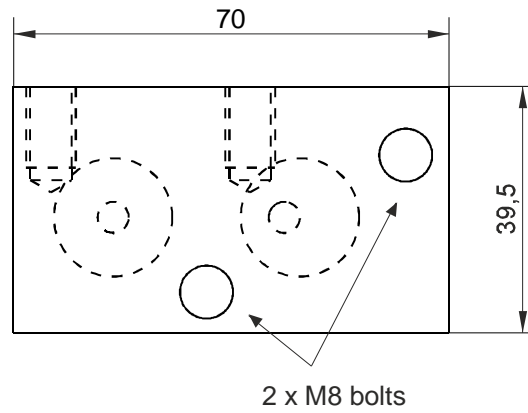

Mounting example

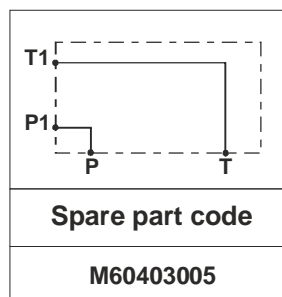
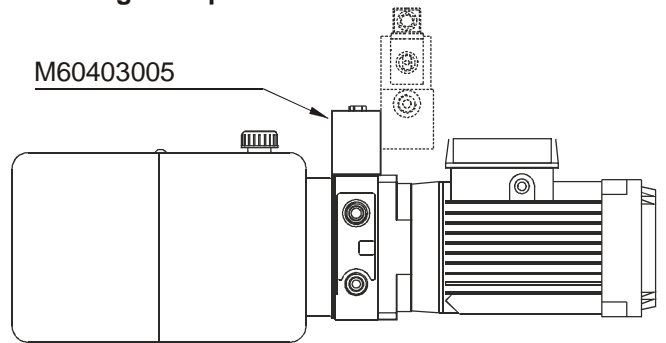

MODULAR MANIFOLDS FOR 3/4-16 UNF CARTRIDGES. TWO WAY



Weight: 0,26 kg (0,57lb)
 Fixing system: 4 x M6 tie-rods
 steel class 8.8 or above

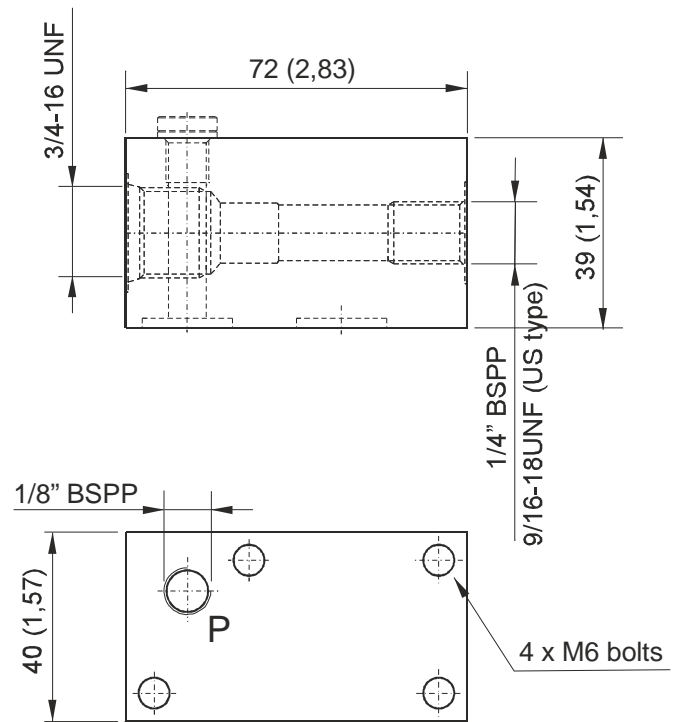

Circuit example

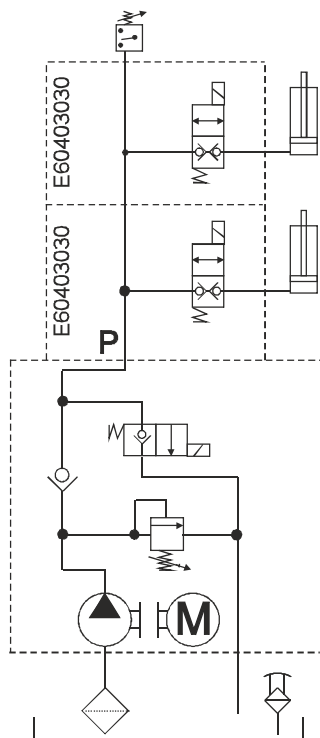

Mounting example

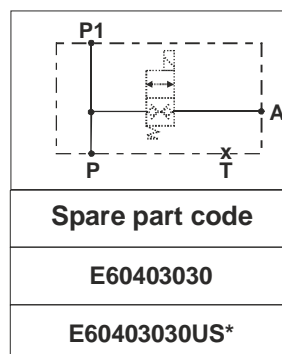
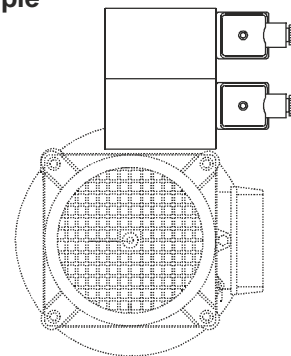

Note: code does not include the MSV or MDV solenoid valve.

Recommended tightening torque for M6 bolts: 8 Nm

*: US execution with 9/16-18 UNF SAE06 exit ports

3/4-16 UNF manifolds can be stacked one upon the other but cannot be used with cetop 3 modular manifolds since the tie rods bolt pattern is different. The three way block is not compatible with square vertical tanks.

MODULAR MANIFOLDS FOR 3/4-16 UNF CARTRIDGES. THREE WAY



Weight: 0,32 kg
 Fixing system: 2xM8 tie-rods
 steel class 8.8 or above

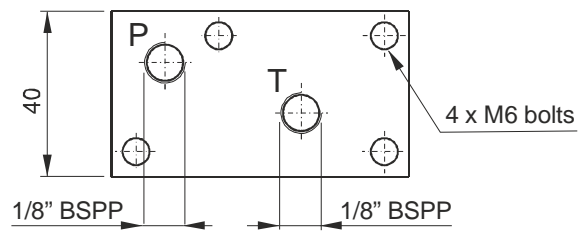
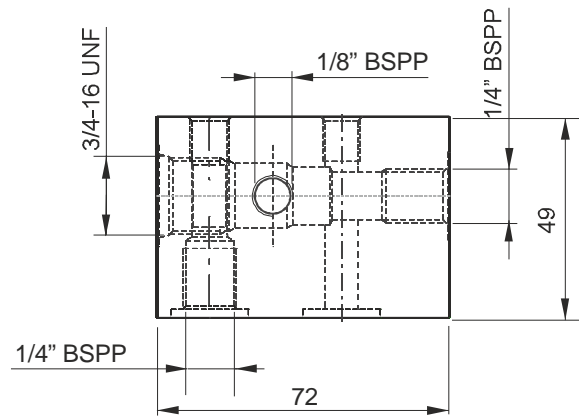

Circuit example

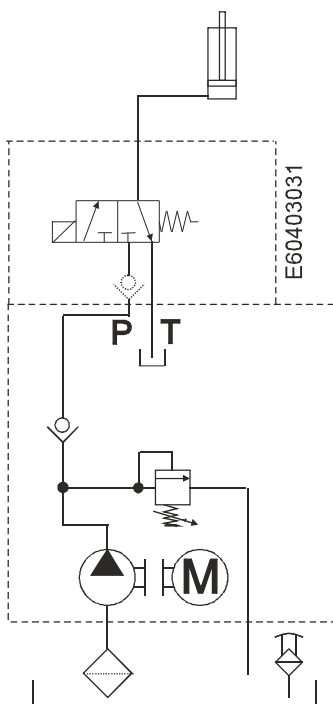

Mounting example

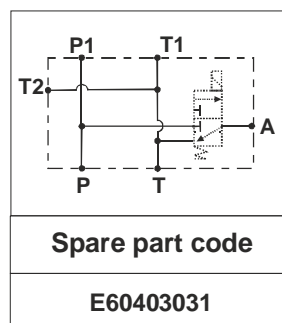
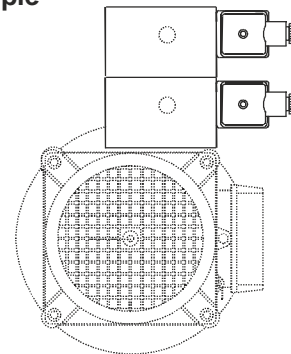

Note: code does not include the MSV3V solenoid valve.

Recommended tightening torque for M6 bolts: 8 Nm

Note: 3/4-16 UNF manifolds can be stacked one upon the other but cannot be used with cetop 3 modular manifolds since the tie rods bolt pattern is different. The three way block is not compatible with square vertical tanks.

ACCESSORIES



In line mounting SAE 8 manifolds

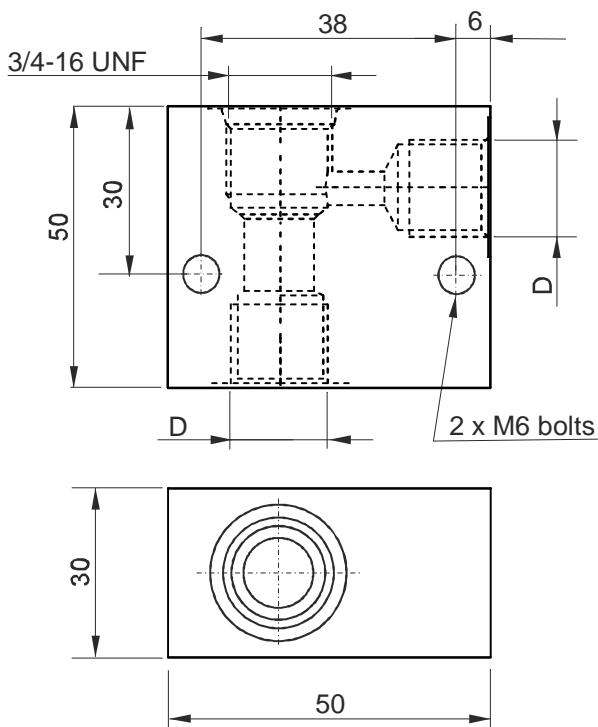

Foot mounting supports

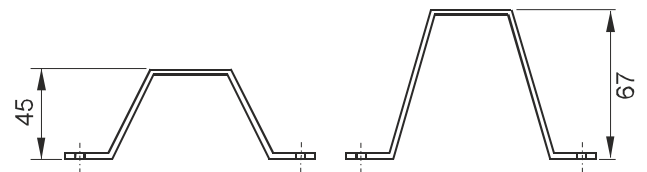

E60543006
Weight: 0,4 Kg

E60543007
Weight: 0,6 Kg

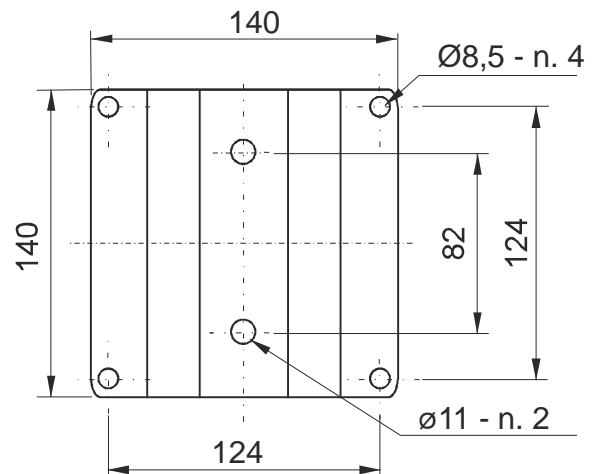

E60543006: suitable for all tanks except E60303012
E60543007: recommended for E60303011, E60303012 tanks and with frame 90 AC integral motors.

Spare part code	D	Weight
BFCSAE0801	1/4" BSPP	0,16 Kg
BFCSAE0802	3/8" BSPP	0,16 Kg

Spare part codes	
E60543006	E60543007

ACCESSORIES



Pressure gauge

Protection degree	IP 65
Thermal drift	±0,04%/1K from 20°C
Weight	0,206 Kg
Static working pressure	75% end of scale
Peak working pressure	end of scale
Working temperature	-10 ÷ +60°C
Precision class	cl. 1.6 EN837-1

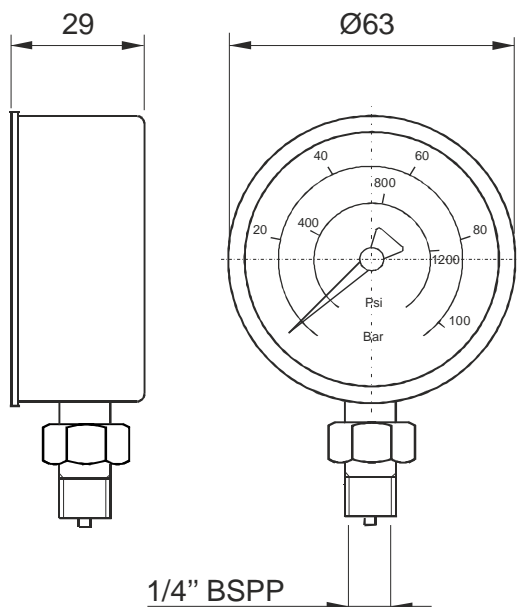

Spare part code	
MIR63***	***:pressure max in bar (60, 100, 160, 250, 315 bar)



Pressure switch

Protection degree	IP 65
Hysteresis	15 ÷ 25%
Weight	0,05 Kg
Max load	0,5A @ 250VAC
Working temperature	-25 ÷ +85°C
Switching accuracy	±4% end of scale @ 20°C
Electric switch	NO / NC

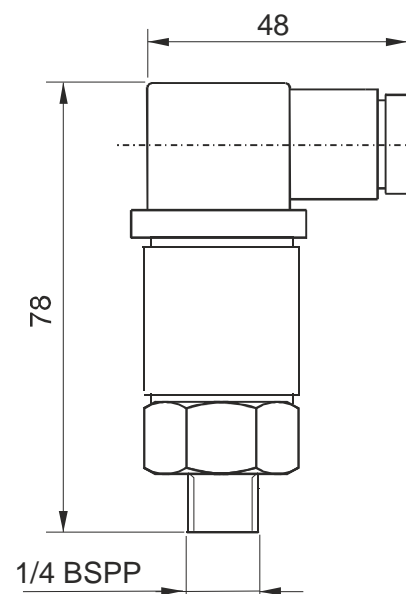

Spare part code	
F401***	***:pressure max in bar (050, 100, 200, 400 bar)

ACCESSORIES



Gauge isolator F-F

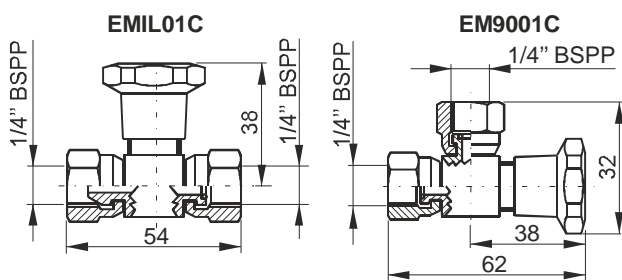

Weight: 0,14 Kg. Max working pressure: bar

Spare part code
EM9001C / EMIL01C



In-line check valve

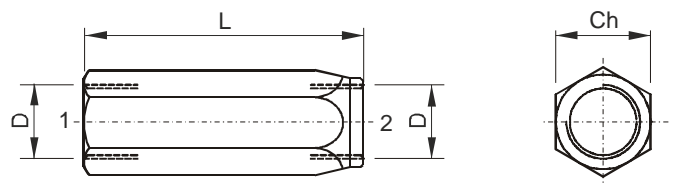

Spare part code	D	Ch	L	Weight
VUR01	1/4" BSPP	19	55	0,10 kg
VUR02	3/8" BSPP	24	65	0,18 kg
VURSAE06	9/16-18UNF	19 (0,75)	58 (2,28)	0,10 kg (0,22 lb)



In-line unidirectional flow control valve

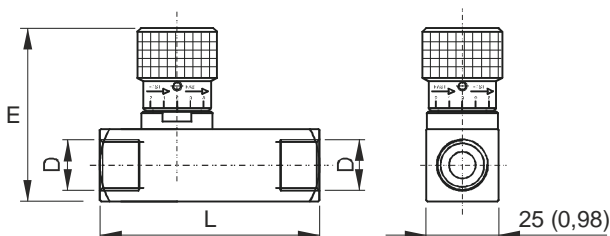

Spare part code	D	E	L	Weight
STU01	1/4" BSPP	68	66	0,34 kg
STU02	3/8" BSPP	68	77	0,36 kg
STUSAE06	9/16-18UNF	68 (2,68)	70,5 (2,78)	0,38 kg (0,84 lb)



In-line bidirectional flow control valve

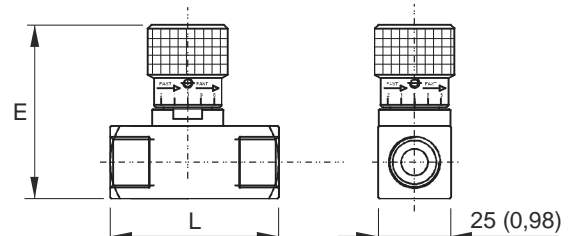

Spare part code	D	E	L	Weight
STB01	1/4" BSPP	68	54	0,29 kg
STB02	3/8" BSPP	68	54	0,27 kg
STBSAE06	9/16-18UNF	68 (2,68)	54 (2,13)	0,30 kg (0,66 lb)

EXTERNAL VALVES

NG3 MICRO directional valves: the optimized solution for top performance with extra compact dimensions. Each valve requires a base modular manifold.



Stackable directional valves: the alternative solution to reduce power pack dimensions and weight. A and B threaded ports are directly machined on the valve body



NG6 (cetop 3) modular sandwich valves: flow control and pressure control. These valves are made with aluminium body and the same functional cartridges used in the power pack central manifold for cost effectiveness and light weight

NG6 (cetop 3) valves: the conventional choice for market compatibility and universal service around the world. Each valve requires a base modular manifold.

Cartridge valves in external blocks: the cost effective and lightweight solution

Which are the advantages of NG3 MICRO directional valves and stackable directional valves compared to NG6 (cetop 3) valves?

Lower weight, lower dimensions, lower cost. Each stackable valve height of just 31 mm can let you build a stack of, for example, 7 valves in 217mm. A similar stack made with cetop 3 valves would be nearly double height. NG3 micro directional valves are to be preferred when other valves (pilot operated check valves, flow controls, pressure controls,...) are added to the hydraulic scheme. They are currently available with 12V or 24V DC coils.

Is it possible to manufacture special manifold blocks with customized valves combinations for specific applications?

Yes. Whenever quantities justify the investment in design and manufacturing. Ask our sales department first.

Which coils and connectors do I select for the spool directional control valves?

NG3 MICRO valves SD00* series use M100 series of coils, 12 or 24 VDC. Stackable valves SD01* series use DC or RAC M120 coils series. NG6 (cetop3) valves SD03* series use M160 series of coils either DC or RAC (rectified current). When choosing a RAC coil, a rectifying bridge connector must be chosen (KA132R***). A standard KA13200000 connector must be always used with DC coils.

NG3 MICRO DIRECTIONAL SOLENOID VALVES



Weight: 0,7 kg (2 sol), 0,55 kg (1 sol)

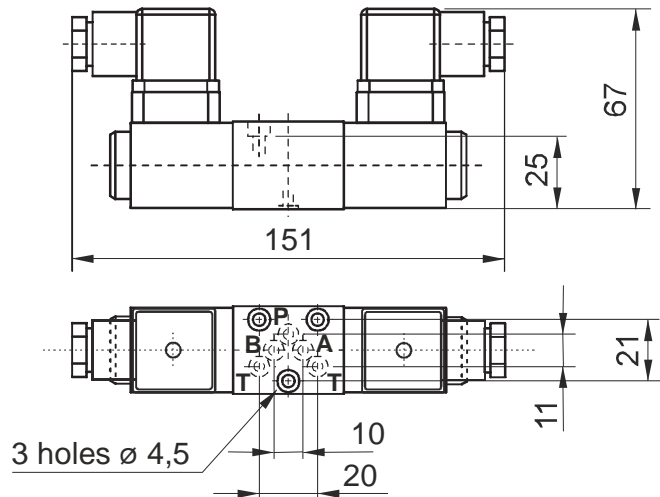

Main features

Max pressure	315 bar
Max p on T port	100 bar
Max flow	15 l/min
Fixing bolts	3 TCEI M4x30. 2,8Nm torque 10.9 class steel or better
Coil insulation	Class H
Electric connection	DIN 43650-A / ISO 4400
Protection class	IP 65 / DIN 40050
Duty cycle	ED 100%
Voltage required	+/- 10% nominal voltage
Manual override	included as standard
Normatives	EN50081-1 / EN50082-2 (89/336 CEE electromagnetic comp.) 73/23/CEE / 96/68/CEE (low voltage)

Spare part code

- SD00** — NG3 micro directional solenoid valve
- A2** — Spool and scheme: see side table
- 24DC** — Supply voltage: see below table
- — Options: - = std

Supply voltage (V)	Coil voltage	Spare coil code	Spare connector code	Holding power consumption
12DC	12DC	M10040001	KA132000B1	16W
24DC	24DC	M10040002	KA132000B1	16W
24AC/50 Hz / 60 Hz	24DC	M10040002	KA132R11B1	16W

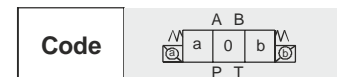

Double solenoid

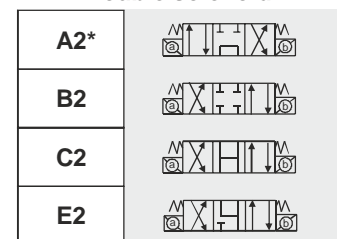

Single solenoid

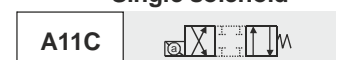

Other voltages and electric connectors types (Amp Junior, flying leads,...) available on request. Inrush power consumption can be up to 3,5 times higher than the holding one.

* = spools with price addition. Other spools are available on request

STACKABLE DIRECTIONAL SOLENOID VALVES

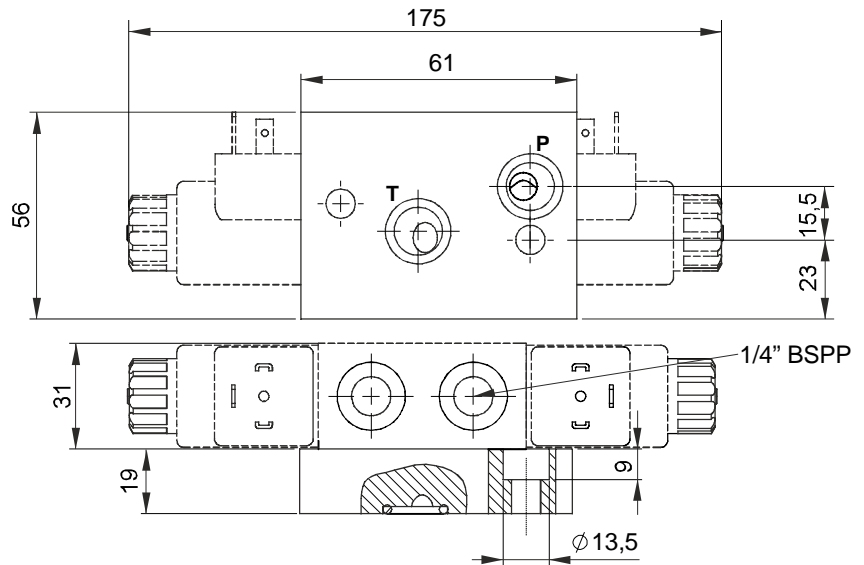
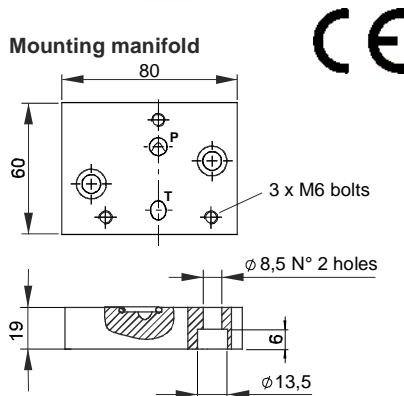

Spare part code: **E60403006**
 Mounting bolts 2 x M8x20
 Weight: 0,22 Kg

Weight: 0,89 Kg (1 sol.)
 1,09 Kg (2 sol.)
 Fixing system: 3xM6 tie-rods

Main features

Max pressure	250 bar
Max p on T port	210 bar static, 140 bar dynamic
Max flow	20 l/min
Fixing bolts	3 TCEI M6 x 6Nm torque. 10,9 class steel
Coil insulation	Class H
Electric connection	DIN 43650-A / ISO 4400
Protection class	IP 65 / DIN 40050
Duty cycle	ED 100%
Voltage required	+/- 10% nominal voltage
Manual override	included as standard
Normatives	EN50081-1 / EN50082-2 (89/336 CEE electromagnetic comp.) 73/23/CEE / 96/68/CEE (low voltage)

Spare part code

- SD01** — Stackable directional solenoid valve
- A2** — Spool and scheme: see side table
- 24DC** — Supply voltage: see below table
- — Position type: - = intermediate
C = top closed

Supply voltage (V)	Coil voltage	Spare coil code	Spare connector code	Holding power consumption
12DC	12DC	M12040001	KA132000B1	22W
24DC	24DC	M12040002	KA132000B1	22W
24AC/50 Hz 60 Hz	24DC	M12040002	KA132R11B1	22W
230AC/50 Hz 60 Hz	220RC	M12040005	KA132R13B1	22W

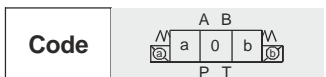

Double solenoid

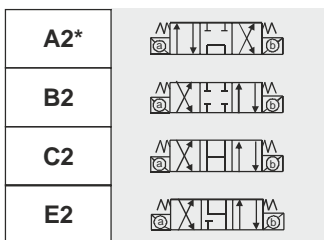

Single solenoid



Other voltages and electric connectors types (Amp Junior, flying leads,...) available on request.

Inrush power consumption can be up to 3,5 times higher than the holding one.

* = spools with price additional. Other spools available on request

NG6 (CETOP 3) DIRECTIONAL SOLENOID VALVES



Weight: 1,43 kg (2 sol), 1,16 kg (1 sol)

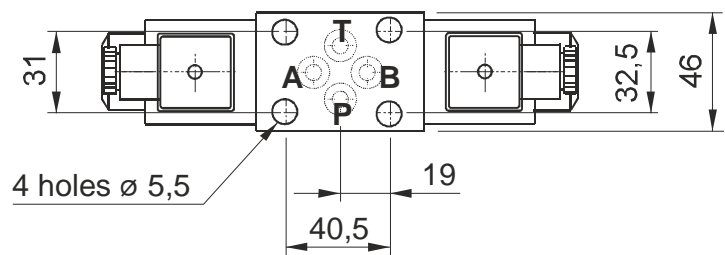
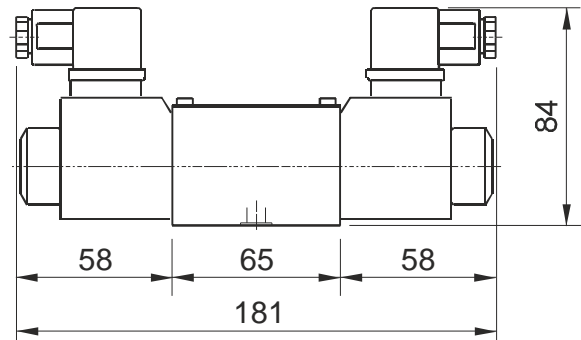

Main features

Max pressure	250 bar
Max p on T port	210 bar static, 180 bar dynamic
Max flow	40 l/min
Fixing bolts	4 TCEI M5x30. 5Nm torque 10.9 class steel or better
Coil insulation	Class H
Electric connection	DIN 43650-A / ISO 4400
Protection class	IP 65 / DIN 40050
Duty cycle	ED 100%
Voltage required	+/- 10% nominal voltage
Manual override	included as standard
Normatives	EN50081-1 / EN50082-2 (89/336 CEE electromagnetic comp.) 73/23/CEE / 96/68/CEE (low voltage)

Spare part code

- SD03** — Cetop 3 directional solenoid valve
- A2** — Spool and scheme: see side table
- 24DC** — Supply voltage: see below table
- — Options: - = std

Supply voltage (V)	Coil voltage	Spare coil code	Spare connector code	Holding power consumption
12DC	12DC	M16040001	KA132000B1	26W
24DC	24DC	M16040002	KA132000B1	26W
24AC/50 Hz / 60 Hz	24DC	M16040002	KA132R11B1	26W
115AC/50 Hz / 60 Hz	110RC	M16040004	KA132R12B1	26W
230AC/50 Hz / 60 Hz	220RC	M16040005	KA132R13B1	26W

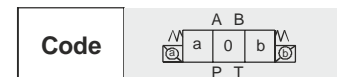

Double solenoid

A2*	
B2	
C2	
E2	

Single solenoid

A11C	
-------------	--

Other voltages and electric connectors types (Amp Junior, flying leads,...) available on request. Inrush power consumption can be up to 3,5 times higher than the holding one.

* = spools with price addition. Other spools are available on request

NG6 (CETOP 3) DIRECTIONAL MANUAL VALVES



Weight: 1,32 kg

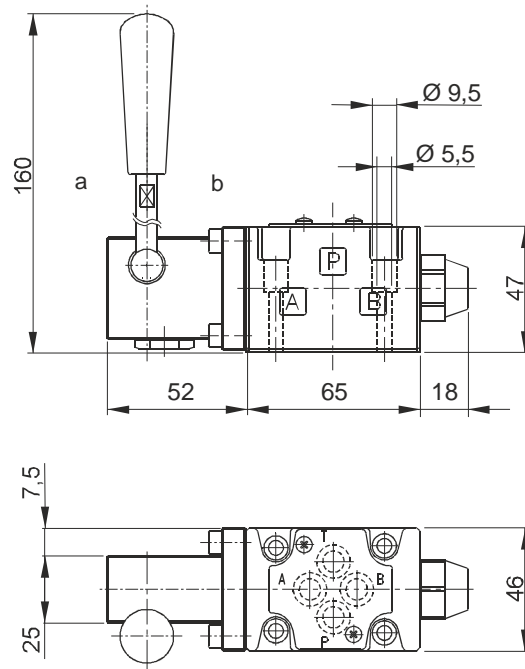

Main features

Max pressure	300 bar
Max p on T port	150 bar
Max flow	30 l/min
Fixing bolts	4 TCEI M5x30. 5Nm torque 10.9 class steel or better
Temperature range	-20 ÷ +80°C
Recommended filtration	25 ÷ 50 μ

Spare part code

- HD03** — Cetop 3 directional manual control valve
- A** — Spool control: see side table
- 1** — Spool type: see side table
- — Options: - = std

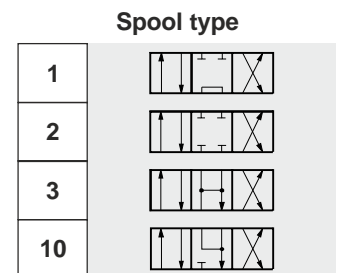
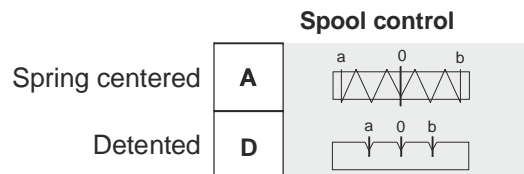

NG6 (CETOP 3) SANDWICH FLOW CONTROL VALVES



Fixing system: 4xM5 tie-rods
steel class 12.9 or above

Mounting example

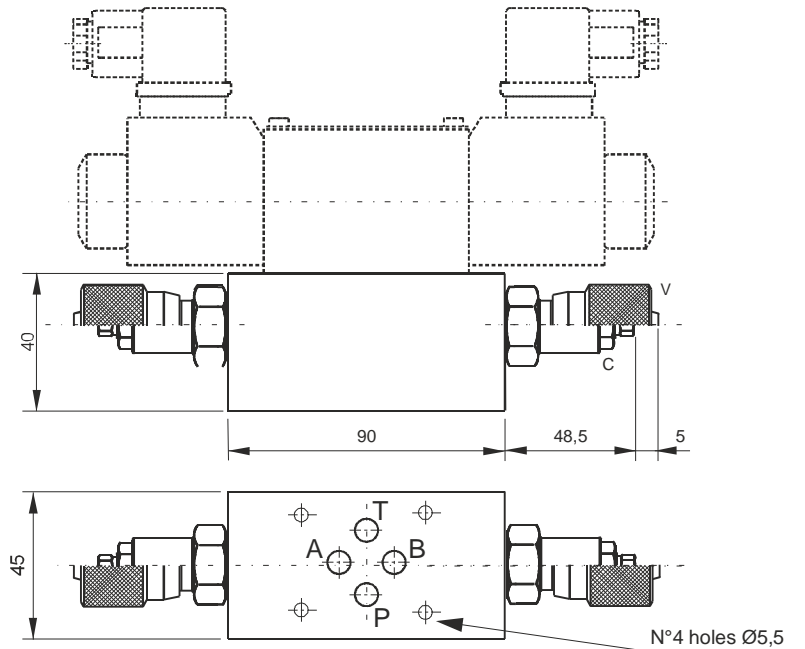
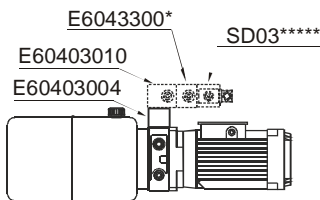

Main features

Max pressure	300 bar
Max flow	15 l/min
Weight	Single relief: 0,52 kg Double relief: 0,64 kg

Recommended filtration settings: 25 ÷ 50 µ
Oil temperature: -30 ÷ + 80 °C

- E60433001** — Cetop3 sandwich meter-out flow control valve
- C** — Adjusting device:
C = screw (std)
V = handwheel

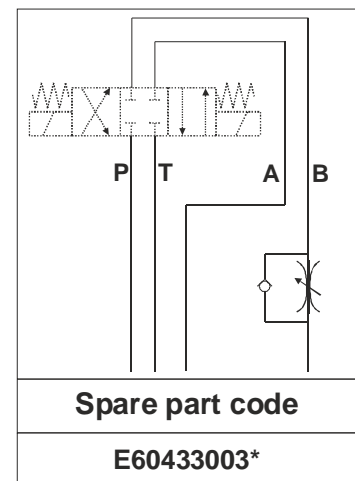
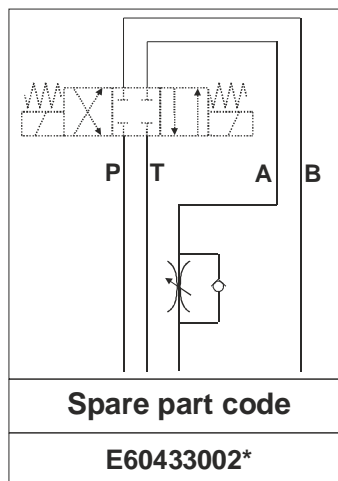
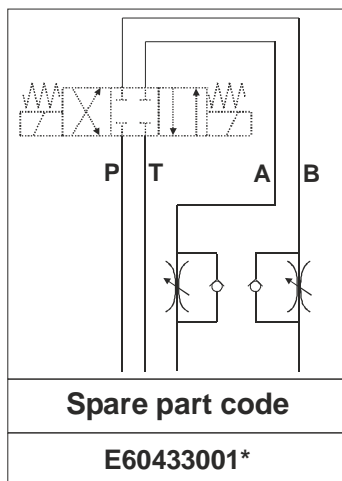

Notes: code does not include the Cetop solenoid valve.

NG6 (CETOP 3) SANDWICH RELIEF VALVES

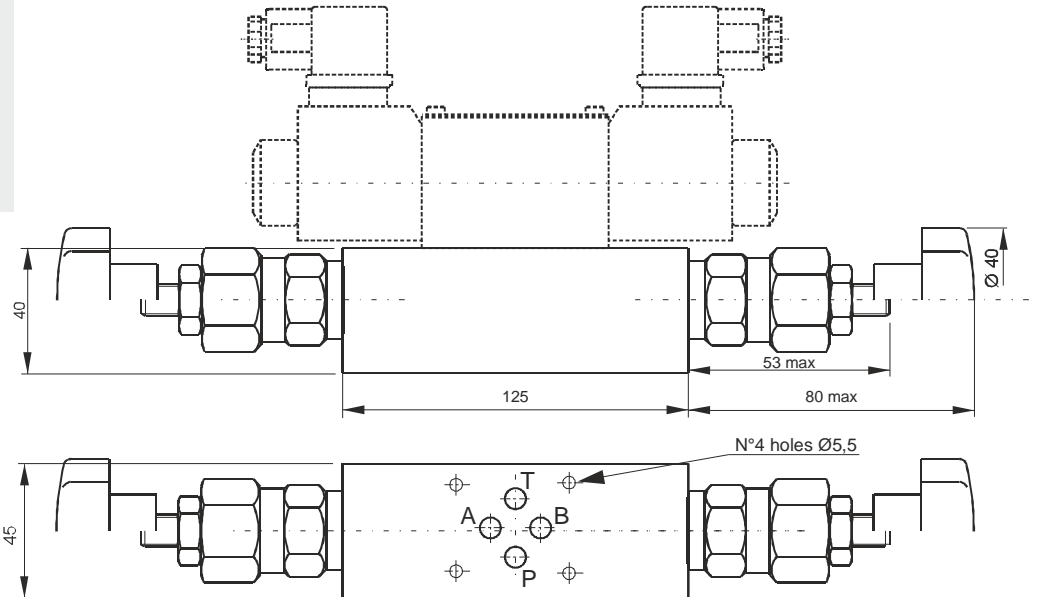

Mounting example

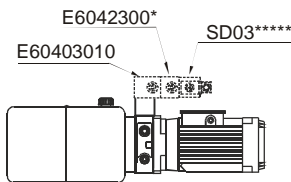

Main features

Max pressure	350 bar
Max flow	35 l/min
Weight	Single relief: 0,71 kg Double relief: 0,87 kg

Recommended filtration settings: 25 ÷ 50 µ
Oil temperature: -30 ÷ + 80 °C

Fixing system: 4xM5 tie-rods
steel class 12.9 or above

- E6042300*** — Cetop3 sandwich relief valve
- B** — Pressure range settings:
L = 10 ÷ 60 bar
A = 20 ÷ 180 bar
B = 35 ÷ 280 bar
- 1** — Option:
1 = screw (std)
2 = handwheel
3 = with cap
4 = plastic seal

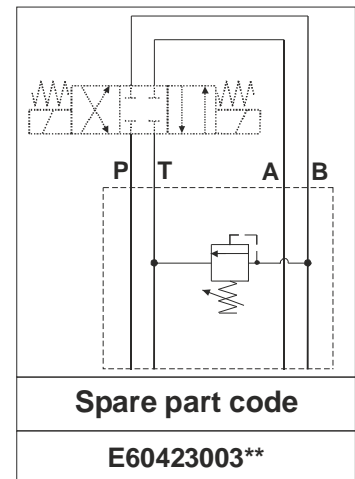
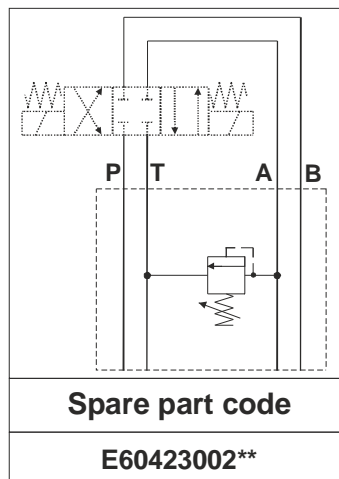
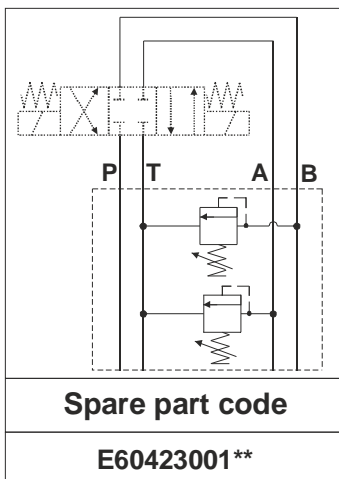

Notes: code does not include the Cetop solenoid valve. When E60423001 relief valves have different pressure ranges, please specify them separately.
Es: E60423001AB=180 bar max for valve on A port, 280bar max for valve on B one.

MSV3V - DIRECT OPERATED 3/2 WAY DIRECTIONAL SPOOL SOLENOID VALVE

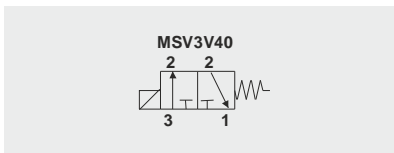
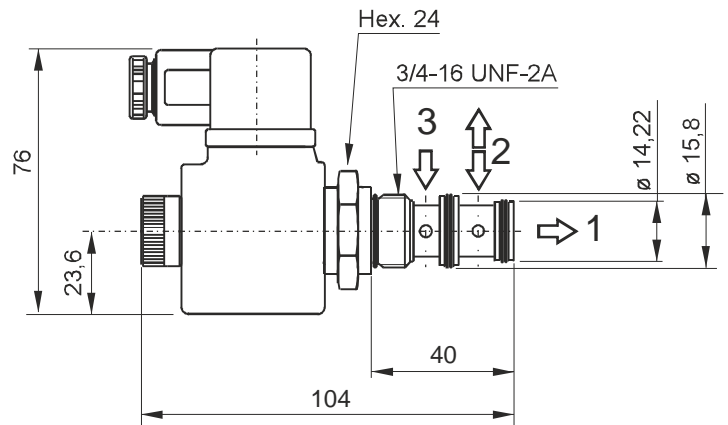

Main features

Max pressure	210 bar
Max flow	12 l/min (20 l/min with no block)
Weight	0,35 Kg (with coil)
Coil thermal insulation	Class H
Electric connection	DIN 43650-A / ISO 4400
Coil protection class	IP 65 / DIN 40050
Duty cycle	ED 100%
Voltage required	+/- 10% nominal voltage
Recommended tightening torque	30 Nm
Oil temperature	-25 ÷ +70°C

Spare part code

MSV3V	Three-way pilot operated solenoid valve
40	Spool type: 40 = std
0	Options: 0 = no options (std) E = emergency
0000	Supply voltage: 0000 = no coil (std) see below table

Coils selection

Supply voltage (V)	Coil type	Spare coil code	Spare connector code	Holding power consumption
12DC	12DC	M14040001	KA132000B1	22W
24DC	24DC	M14040002	KA132000B1	22W
24AC/50 Hz 60 Hz	24DC	M14040002	KA132R11B1	22W
115AC/50 Hz 60 Hz	110RC	M14040004	KA132R12B1	22W
230AC/50 Hz 60 Hz	220RC	M14040005	KA132R13B1	22W

Pressure drop diagram

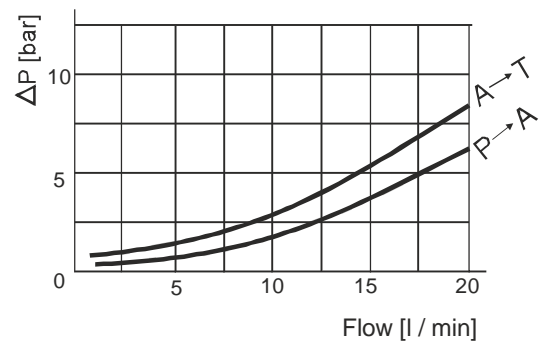

Other voltages and electric connectors types (AMP JUNIOR, flying leads,...) are available on request.
Inrush power consumption can be up to 3,5 times higher than the holding one.